

BAXTER

DOUBLE OVEN RACK

ITEM NUMBER _____
QUANTITY NO. _____
JOB NO. _____
SPEC NO. _____

Baxter Double Oven Rack

SPECIFICATIONS:

- All Welded Stainless Steel Construction
- Side Loading
- 15 Slides, 4" Spacing, 30 Pan Capacity
- Slides Are 16 Gauge, 1 1/2" Wide
- 10 Gauge Base Plate With Swivel
- High temperature oven casters with bushings, no greasing required
- Overall Dimensions are 28 3/8" Wide x 36" Deep x 69 5/8" Tall

Heavy Duty Base Construction



DO-154-B/16



*SPECIAL DESIGN BASE PLATE

NO MORE ⚡ BROKEN WELDS!



BEST IN THE INDUSTRY



BAXTER DOUBLE OVEN RACK

BAXTER

DOUBLE OVEN RACK

ITEM NUMBER _____
QUANTITY NO. _____
JOB NO. _____
SPEC NO. _____

MODEL: DO-154-B/16

DIAGRAMS

BAXTER DOUBLE OVEN RACK

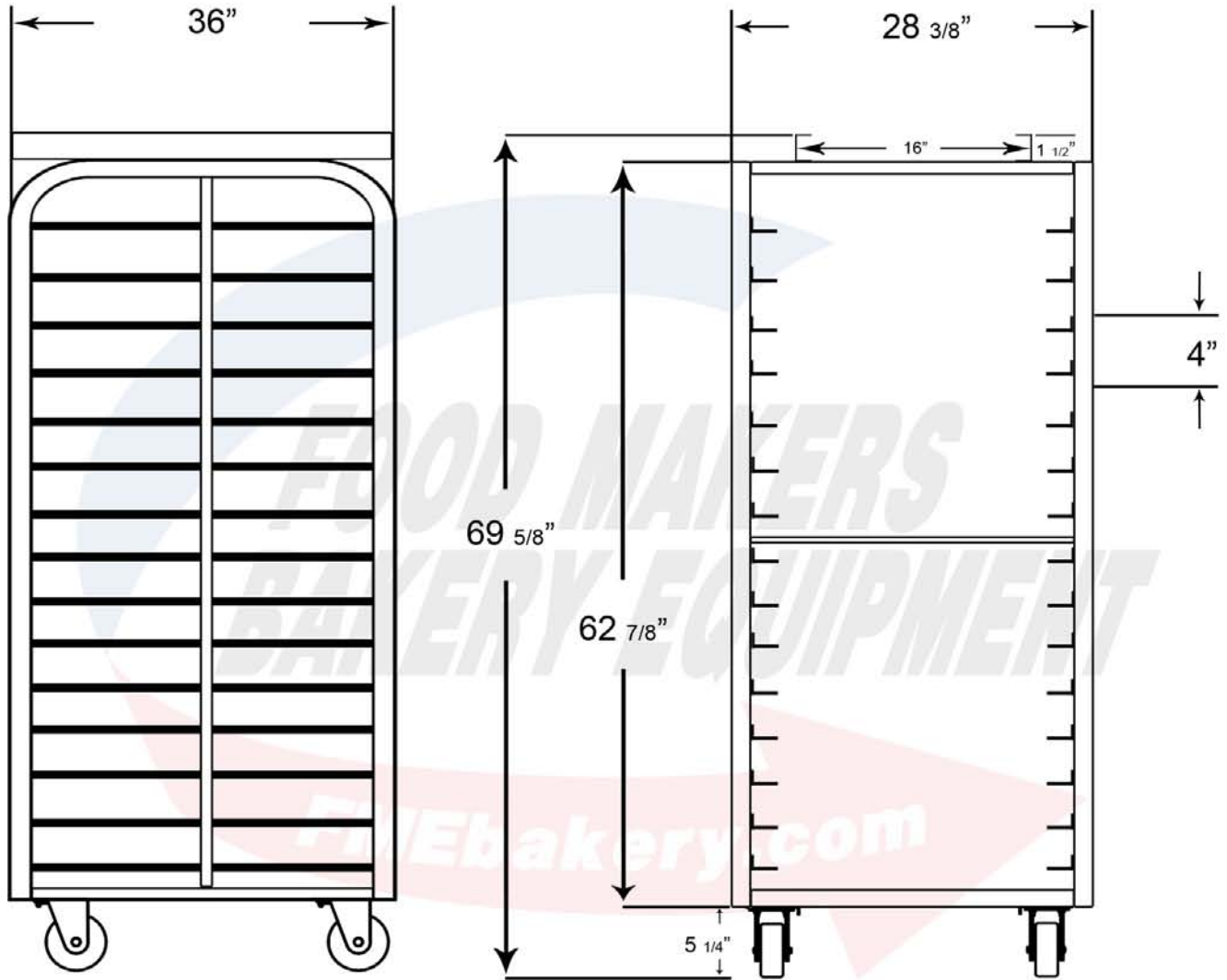

Side View

Front View

Food Makers Bakery Equipment manufactures only the highest quality racks. All our racks have a base plate construction with full swivel casters to ensure heavy duty capacity. All welded construction allows us to guarantee our racks for a lifetime of ownership, excluding casters.

Custom racks are no problem, send us your specifications and we will build to order.

