



Item: _____
Quantity: _____

MT Series Revolution Oven Gas Fired

Standard Features

- Natural or propane gas
- Stainless steel exterior walls (side 1 & facade), galvanized steel (side 2 & back) and aluminized steel interior walls/roof
- Panoramic window above the loading door
- Aluminum counter-balanced door
- Digital control
- Loading door with 8 1/2" high opening
- Numbered solid steel or expanded metal shelves with 3" back riser
- 2 lights inside the oven
- Front access doors to driving system, gas and electrical components
- Available with 8, 12, 16 or 24-pan capacity

Options

- Exhaust canopy (Type II) with motor extractor
- Self-generating steam system
- Baking stone shelves (1/2" thickness)
- Aluminum vertical door of 11 3/4" high opening
- Stainless steel floor and main shaft
- 4 timers
- Preset timer

Models

- MT-4-8 (8-pan)
- MT-4-12 (12-pan)
- MT-8-16 (16-pan)
- MT-8-24 (24-pan)

*Specifications and details on back.

Installation

An authorized technician from Picard will take care of the unloading and installation at the customer's site. All oven parts can pass through a regular 36" x 80" door and can be moved by hand. All electrical, gas, water, and chimney hook-ups, along with the oven burner's start-up, are at the customer's expense and have to be done by the qualified installation technician and according to local codes.



MT Series Revolution Oven

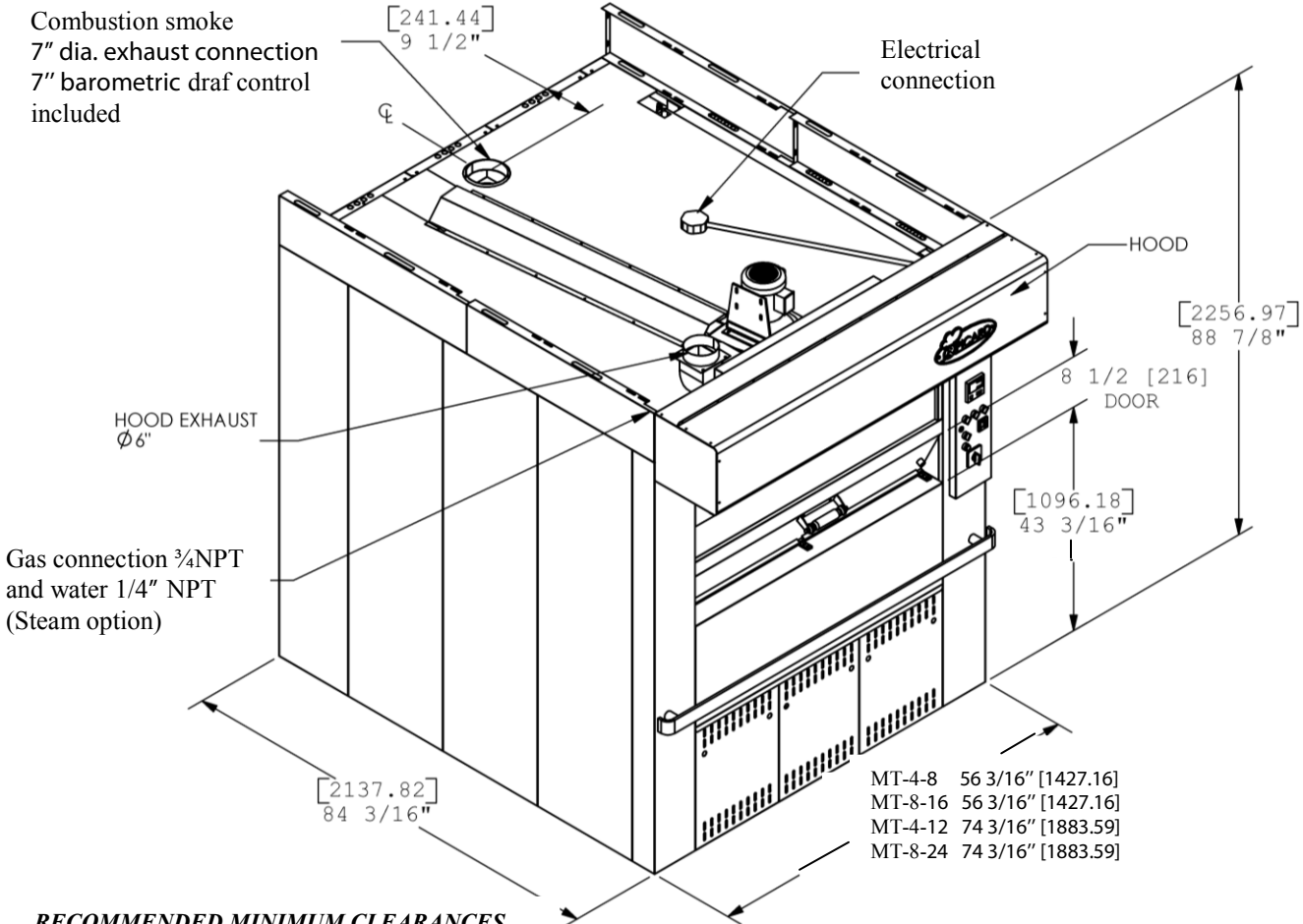

RECOMMENDED MINIMUM CLEARANCES

Floor to ceiling	Sides and Back to Wall	Floor
96"	0"	Approved for combustible surface

GAS SUPPLY SPECIFICATIONS

	Min. Gas Pipe Size	Manifold Pressure	Power (BTU/HR)			
			MT-4-8	MT-8-16	MT-4-12	MT-8-24
Natural Gas	3/4" NPT	3.5" W.C.	135 000	135 000	180 000	180 000
Propane Gas	3/4" NPT	11" W.C.	135 000	135 000	180 000	180 000

ELECTRICAL RATING

Model	Voltage	Phase	Hertz	(1) Amps	Supply
MT-4-8	115 V	1	60	13	3 wire including neutral and ground
MT-8-16				19	
MT-4-12				13	
MT-8-24				19	

GAS SUPPLY SPECIFICATIONS

Model	(2) Ship Weight	Crate dimensions		
MT-4-8	2 300 lbs	64"	92"	85"
MT-8-16		64"	92"	85"
MT-4-12	3 000 lbs	82"	92"	85"
MT-8-24		82"	92"	85"

(1) Hood (option) add 4 Amps.

(2) Steam (option) add 500 lbs.

BAKING CAPACITIES

Model	Trays		Bagels	Breads			Pies		Pizzas					
	Qty	Size	5 oz	Pans (18" x 26")	1 lb	1.5 lb	9"	8"	10"	12"	14"	16"	18"	
MT-4-8	4	26" X 36 1/2"	120	8	60	48	36	44	24	16	12	8	8	
MT-8-16	8	26" X 36 1/2"	240	16	120	96	72	88	48	32	24	16	16	
MT-4-12	4	26" X 54 1/2"	200	12	80	64	56	64	32	32	16	12	12	
MT-8-24	8	26" X 54 1/2"	400	24	160	128	112	128	64	64	32	24	24	

* Continuous product development is a Picard policy. Therefore, we reserve the right to change specifications and/or design without prior notice.