



Item No. _____
 Project _____
 Quantity _____

BakerSeries Reversible Dough Sheeter

MODEL: RDS - Series



Model RDS 10/24 shown

PRODUCTION CAPACITY GUIDE

| Capacity / Model | RDS-10/20 | RDS-10/24 |
|------------------|-----------|-----------|
| Belt Width | 20" | 24" |
| Table Length | 50" | 50" |

Short Bid Specification:

Dough Sheeter shall be a LBC Bakery Equipment Model RDS [insert 10/20 or 10/24] 3-phase 208 / 240 VAC reversible dough sheeter. Sheeter shall be equipped with 6' power cored with twist lock plug. Feed belt shall be seamless, non-absorbing Rayon. Stainless steel catch trays shall be supplied at both ends of feed tables. Feed tables shall be aluminum and shall be foldable for storage and shall include attached baton (rolling pin). Base and all attached surfaces shall be stainless steel. Head assembly shall be polished aluminum. Controls shall include infinitely adjustable roller pressure, adjustable final roller height stop position, On/Off switch, safety interlock switches at the in-feed guards and motor direction foot controls. Dry type clutch drive shall automatically overdrive out-feed belt by 20% in both directions. Dough sheeter shall be ETL listed or equivalent for Safety and Sanitation.

STANDARD PRODUCT WARRANTY

One-Year Parts and 90 days Labor (contiguous US Including Alaska and Hawaii, Canada)

Construction Features

- Non-absorbant Rayon® Belts
- Stainless steel base
- Non-painted construction
- Polished Aluminum head assembly
- Nylon rollers
- Stainless steel in-feed hand and finger guard
- Folding aluminum feed tables
- Rear outrigger legs with adjustable feet
- Locking Casters
- Extendable stainless steel end trays
- Baton (Rolling Pin) with floating and park position bracket

Performance Features

- 1 HP 3 Phase drive motor
- Full reversing motor operation
- Dry clutch feed belt drive
- Automatic belt speed compensation in both directions
- 20% overdrive on outfeed belt

Controls Features

- Infinitely adjustable roller height
- Pistol grip roller adjustment with release lock
- Adjustable final roller position stop
- Foot control switch (Left/Right)
- Rotary On/Off switch



Meets UL 763 and NSF-8 Standards

Food Makers Bakery Equipment

16019 Adelante Street Irwindale, CA 91702

Phone: 626-358-1343 FAX: 626-334-0970

Sales@fmebakery.com

www.fmebakery.com

BakerSeries Reversible, Dough Sheeter

MODEL: RDS - Series

INSTALLATION REQUIREMENT: 208-240 VAC, 50-60 Hz. 3Phase, 20 Amps, NEMA L15-20 Receptacle

OPTIONS & ACCESSORIES: Baton (Rolling Pin)

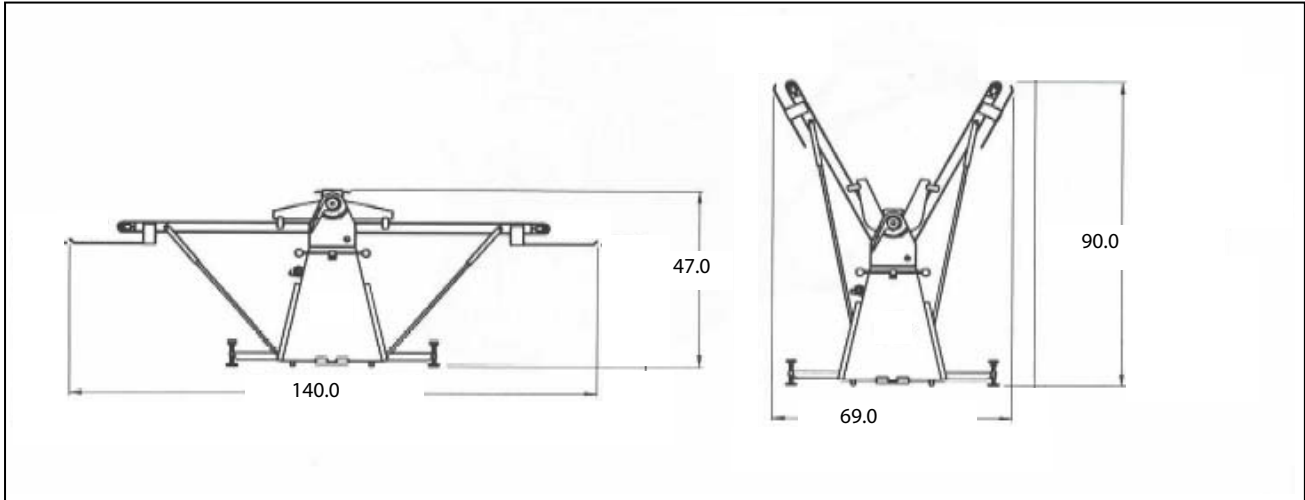

| Model | Dimensions Height x Width x Depth | | Clearance from Combustibles | | Weight | | Freight Class |
|-----------|-----------------------------------|--------------|-----------------------------|-----|--------|----------|---------------|
| | Extended | Retracted | Sides and Back | Top | Actual | Shipping | |
| RDS-10/20 | 47 x 140 x 45 | 90 x 69 x 45 | 0" | 0" | 625 | 745 | 85 |
| RDS-10/24 | 47 x 140 x 40 | 90 x 69 x 40 | 0" | 0" | 625 | 745 | 85 |
| | | | | | | | |
| | | | | | | | |

| Electrical Specifications By Model | | | | | |
|------------------------------------|-------|-----------|------|-----------|------|
| Voltage | Phase | RDS-10/20 | | RDS-10/24 | |
| | | HP | Amps | HP | Amps |
| 208 VAC 60Hz | 3 | 1 | 12 | 1 | 12 |
| 240 VAC 60Hz | 3 | 1 | 12 | 1 | 12 |

Sheet Number RDS (rev 06/06)

Food Makers Bakery Equipment

16019 Adelante Street Irwindale, CA 91702

Phone: 626-358-1343 FAX: 626-334-0970

Sales@fmebakery.com

www.fmebakery.com