

● Pesì / Misure  
Weight / Dimensions

MOD.	Motore spezzatrice Divider motor	Motore tappeto Conveyor motor	Produzione oraria Hourly output	Pezzature Weight range	Massa macchina Netto / con imballo Weight of machine Net / with packing	Misure machine con imballo Packing dimensions
	kW/HP	kW/HP	Pz/H min/max	Kg / LBS min/max	Kg / LBS	mm (LxPxH) inches
SVP0 SVP0/R	1,1/1,5	0,18/0,25	540/1620 1080/3240	90/900 - 0,198/1,98 30/200 - 0,066/0,44	775/805 - 1661/1771 760/810 - 1672/1782	1740x1140x1950 68,5x45x77
SVP1 SVP1/R	1,1/1,5	0,18/0,25	540/1620 1080/3240	200/1700 - 0,44/3,74 50/300 - 0,11/0,66	775/805 - 1661/1771 760/810 - 1672/1782	1740x1140x1950 68,5x45x77
SVP2 SVP2/R	1,1/1,5	0,18/0,25	540/1620 1080/3240	300/2700 - 0,66/5,94 100/500 - 0,22/1,1	775/805 - 1661/1771 760/810 - 1672/1782	1740x1140x1950 68,5x45x77
SVP3 SVP3/R	1,1/1,5	0,18/0,25	540/1620 1080/3240	500/4000 - 1,1/8,8 250/1000 - 0,55/2,2	775/805 - 1661/1771 760/810 - 1672/1782	1740x1140x1950 68,5x45x77

\* Il diametro della tramoggia varia a seconda della capacità di pasta richiesta

\* The hopper diameter changes according to the required dough capacity

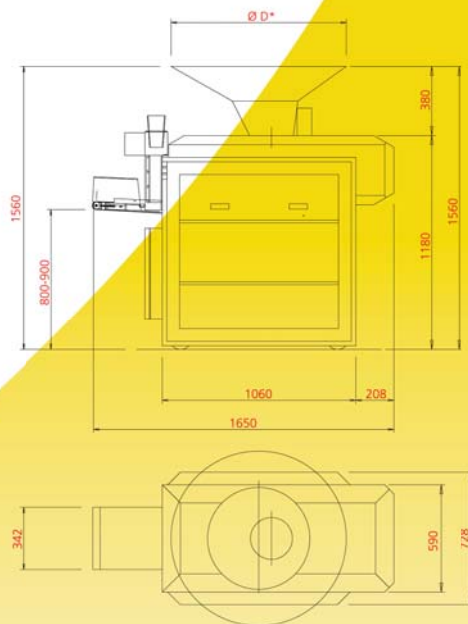

FOOD MAKERS BAKERY EQUIPMENT  
16019 ADELANTE STREET  
IRWINDALE, CA 91702-3255  
Visit our website at: [www.fmebakery.com](http://www.fmebakery.com)

[www.integracom.it](http://www.integracom.it)

cod. 35275227-20 Rev. 0

È presso della Ditta apporre continue miglioramenti ai prodotti, perciò, i dati del presente catalogo sono parzialmente indicativi. The Company's policy is one of continuous improvement and development, therefore specifications are subject to change without notice.



**SVP**  
**SPEZZATRICE VOLUMETRICA**  
**BREAD DIVIDER**



# SVP

## SPEZZATRICE VOLUMETRICA BREAD DIVIDER

Macchina per porzionare una massa di pasta in pezzi di peso desiderato da inviare poi alle lavorazioni successive (arrotondatura, puntatura, filonatura, ecc.). Struttura portante in fusione di ghisa. La macchina è prevista in 4 versioni: SVP0, SVP1, SVP2 e SVP3 che si differenziano tra loro per il volume e quindi la massa dei pezzi di pasta ottenibili. Abbinabile ai sollevatori mod. SC, SRCV e alle impastatrici con ribaltatore mod. PRISMA, previa dotazione della macchina con tramoggia di adeguata capacità.

*This machine has been designed for portioning the dough in pieces of the desired weight and undergo them to further processing (rounding, resting, long-loaf moulding, etc.). Cast iron support structure. The machine is available in four versions: SVP0, SVP1, SVP2 and SVP3 that are different from each others because of the volume and the weight of the dough pieces which can be obtained. This divider can be coupled to SC and SRCV lifting tilting devices and to lifting-tilting mixers mod. PRISMA, once the machine has been provided with a hopper of suitable capacity.*

## Abbinamenti Couplings

La Spezzatrice SVP può essere alimentata da un'impastatrice autoribaltante o da un sollevatore per carrelli e può inoltre essere abbinata a varie macchine quali arrotondatrici o formatrici. Abbinamento ad arrotondatrici coniche o a nastri contrapposti per paste particolarmente appiccicose.

**Tramoggia di carico in acciaio inox** della capacità di 80 kg (176 lbs ca.) di pasta, con possibilità di ulteriori tramogge maggiorate per l'abbinamento a sollevatori rovesciatori o a impastatrici autoribaltanti.

*SVP divider can be fed by a self tilting spiral mixer or by a trolleys lifter and moreover can be coupled to different type of machines like rounders and moulders. Coupling to conical rounders or opposite belts rounders for particularly sticky doughs.*

**Loading hopper in s/steel** with capacity of approx. 80 kg (176 lbs) of dough, with possibility of additional larger hoppers for coupling to lifting tilting machines or self-tilting spiral mixers.



## Linea pane Bread Line

LINEA PER PANE GROSSO E FILONI COMPOSTA DA:  
Sollevatore Rovesciatore Mod. SC  
Spezzatrice Volumetrica Mod. SVP  
Arrotondatrice a Cono Mod. AS  
Cella di Lievitazione Intermedia Mod. CLI  
Filonatrice Mod. F4

**BREAD LINE COMPOSED BY:**  
Lifting-tilting machine Mod. SC  
Bread divider Mod. SVP  
Conical Rounder Mod. AS  
Pre-rising prover Mod. CLI  
Long-loaf Moulder Mod. F4



**FOOD MAKERS  
BAKERY EQUIPMENT**

FMEbakery.com