

STAINLESS STEEL END LOAD PAN RACK

STAINLESS STEEL END LOAD PAN RACK

ITEM NUMBER _____

QTY. NUMBER _____

JOB NUMBER _____

SPEC. NUMBER _____



Shown Here
SPE-203

SPECIFICATIONS:

- **Stainless Steel Construction**
16 Gauge Slides, 12 Gauge Baseplate
- **All Welded Frame**
- **Indestructible Baseplate**
Frame Rests On Baseplate **NOT** On Welds
- **Long Lasting, Durable**
5" x 2" Industrial Wheels
3,200 lbs. Load Capacity
Won't Damage Your Floors
- **Dual Grease Zerks**
 - Prolonged Life
 - Easy Maintenance
- **Lifetime Rack Warranty**
With Double Weld Slide Option



Unmatched Baseplate Design

Won't Ever Warp, Bend or Break. Guaranteed.



Food Makers Bakery Equipment
626-358-1343

www.FMBE.com • sales@fmebakery.com • Irwindale, CA

STAINLESS STEEL END LOAD PAN RACK

STAINLESS STEEL END LOAD PAN RACK

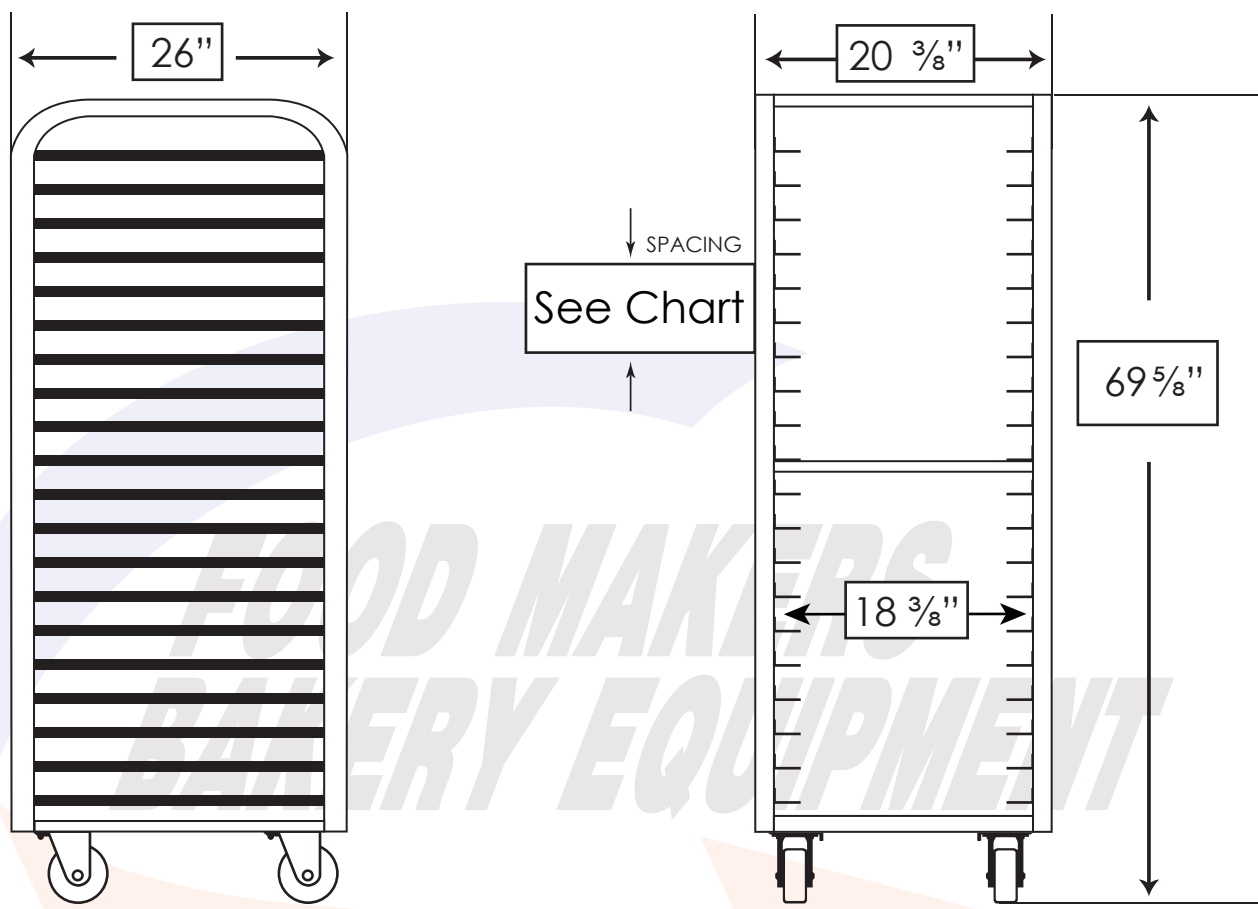

SIDE VIEW

FRONT VIEW

Model	Slides	Slide Spacing	Pan Capacity
SPE-106	10	6"	10
SPE-125	12	5"	12
SPE-154	15	4"	15
SPE-1735	17	3 1/2"	17
SPE-203	20	3"	20
SPE-2425	24	2 1/2"	24
SPE-302	30	2"	30

CUSTOM SIZING



AVAILABLE

OPTIONS:

- Add The Double Weld Option For Lifetime Warranty
- Special Spacing & Height? No Problem! Call Us Today

Food Makers Bakery Equipment
626-358-1343

www.FMBE.com • sales@fmebakery.com • Irwindale, CA