

Enter **Serial No.** here.

MANUAL No.Y-OM-03E

In the event of an enquiry please quote this serial number.

**Store this document safely and ensure it is available at all times.
Non-availability may affect the service / repair of your machine.**

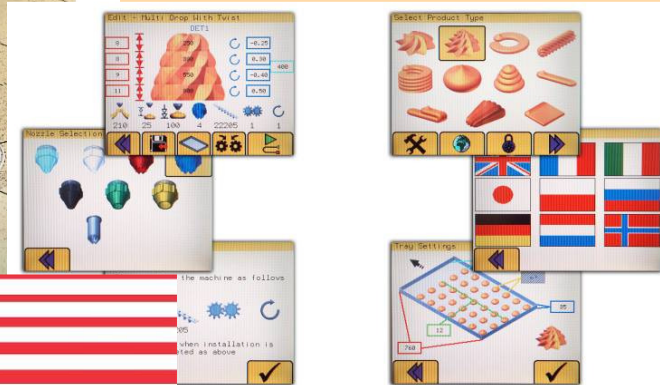
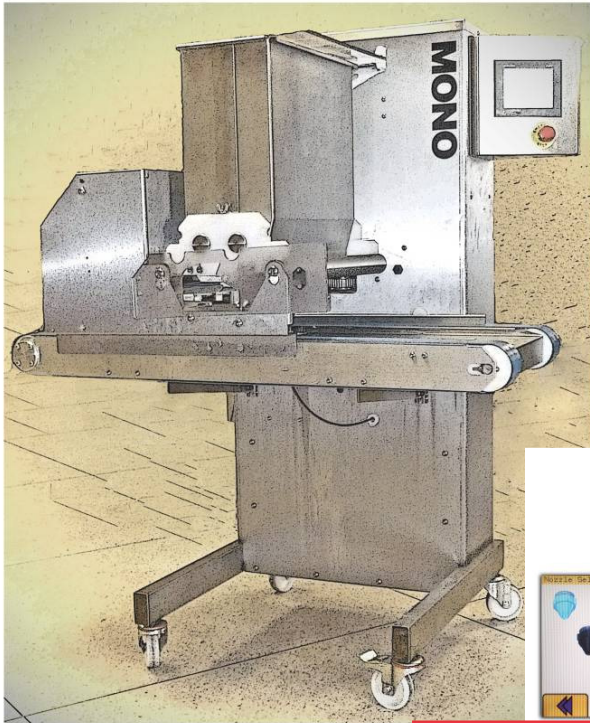

MONO

OPERATING AND MAINTENANCE MANUAL

“OMEGA PLUS”

INCLUDING WIRECUT VERSION DEPOSITOR (400, 450,)

04-06-14
Rev.B14

The use of templates and/or accessories not produced or supplied by MONO Equipment will invalidate the machine's warranty



DECLARATION OF CONFORMITY

We hereby declare that this machine complies with the essential health and safety requirements of :-

- The Machinery Directive 2006 / 42 / EC
- The Low voltage Directive 2006 / 95 / EC
- The requirements of the Electromagnetic Compatibility Directive 2004 / 108EC, 91 / 263 / EEC, 92 / 31 / EEC
- The General Safety of Machinery and food processing Standards applicable
- Materials and Articles intended to come into contact with food Regulation (EC) No. 1935 / 2004

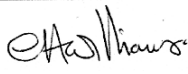
Signed	
G.A.Williams – Quality Manager	

Date	
------	--

Machine FG Code.		Machine Serial No.	
---------------------	--	-----------------------	--

A technical construction file for this machine is retained at the following address:

MONO EQUIPMENT
Queensway,
Swansea West Industrial Park,
Swansea
SA5 4EB
UK

MONO EQUIPMENT is a business name of **AFE GROUP Ltd**
Registered in England No.3872673 VAT registration No.923428136

Registered office: Unit 35,
Bryggen Road,
North Lynn Industrial Estate,
Kings Lynn Norfolk,
PE30 2HZ

QD 080

Revision AA

Dated 06/02/2014

Failure to adhere to the cleaning and maintenance instructions detailed in this booklet could affect the warranty of this machine.

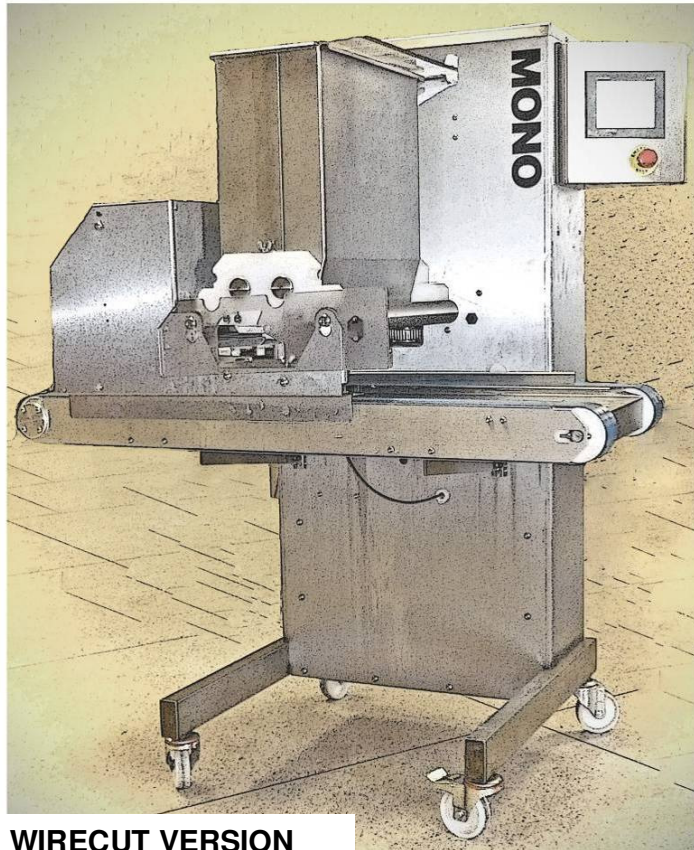

WIRECUT VERSION

FOR SAFE WORKING, PAY SPECIAL ATTENTION TO ITEMS MARKED



The use of templates and/or accessories not produced or supplied by MONO Equipment will invalidate the machine's warranty

- 1.0 - INTRODUCTION
- 2.0 - DIMENSIONS
- 3.0 - SPECIFICATIONS
- 4.0 - SAFETY 
- 5.0 - INSTALLATION
- 6.0 - ISOLATION
- 7.0 - CLEANING INSTRUCTIONS
- 8.0 - OPERATING CONDITIONS
- 9.0 - **PREPARING FOR OPERATION**
 - 9A – FITTING THE HOPPER*
 - 9B – FITTING A TEMPLATE*
- 10.0 - **OPERATING INSTRUCTIONS**
 - 1** – SELECT PRODUCT TYPE
 - 2** – SELECT SAVED NAME OF PRODUCT TYPE
 - 3** – CONFIRM SETUP
 - 4** – OPERATOR SCREEN
 - 5** – EDIT SCREEN
 - 5A** – TRAY SETUP
 - 6** – COPY
 - 7** – DELETE
 - 8** – PASSWORDS
 - 9** – ENGINEERING SETTINGS
 - 10** – FAULT INFORMATION SCREENS
- 11.0 - MAINTENANCE CHECK AND MAINTENANCE SCHEDULE
- 12.0 - SPARES AND SERVICE
- 13.0 - SPARES LIST
- 14.0 - ELECTRICAL INFORMATION

1.0 INTRODUCTION

Omega
PLUS

- The innovative “five axis deposit” design of MONO’s “**Omega PLUS**” and “**Omega PLUS with wirecut**” depositor allows it to recreate most of the hand movements of the Master confectioner. This makes the “**Omega PLUS**” capable of exceptional accuracy of product weight, size and shape.
- Maintenance is kept to a minimum and the smooth body design makes daily cleaning quick and easy.
- Easy to use computer software gives access to 650 programs, which are stored in the memory and easily recalled for use or modification. Control is via a colour touch screen with graphically represented products, already installed, that can be created or edited to the required product.
- It is available with soft and hard dough hoppers. There is also a large selection of templates and nozzles.

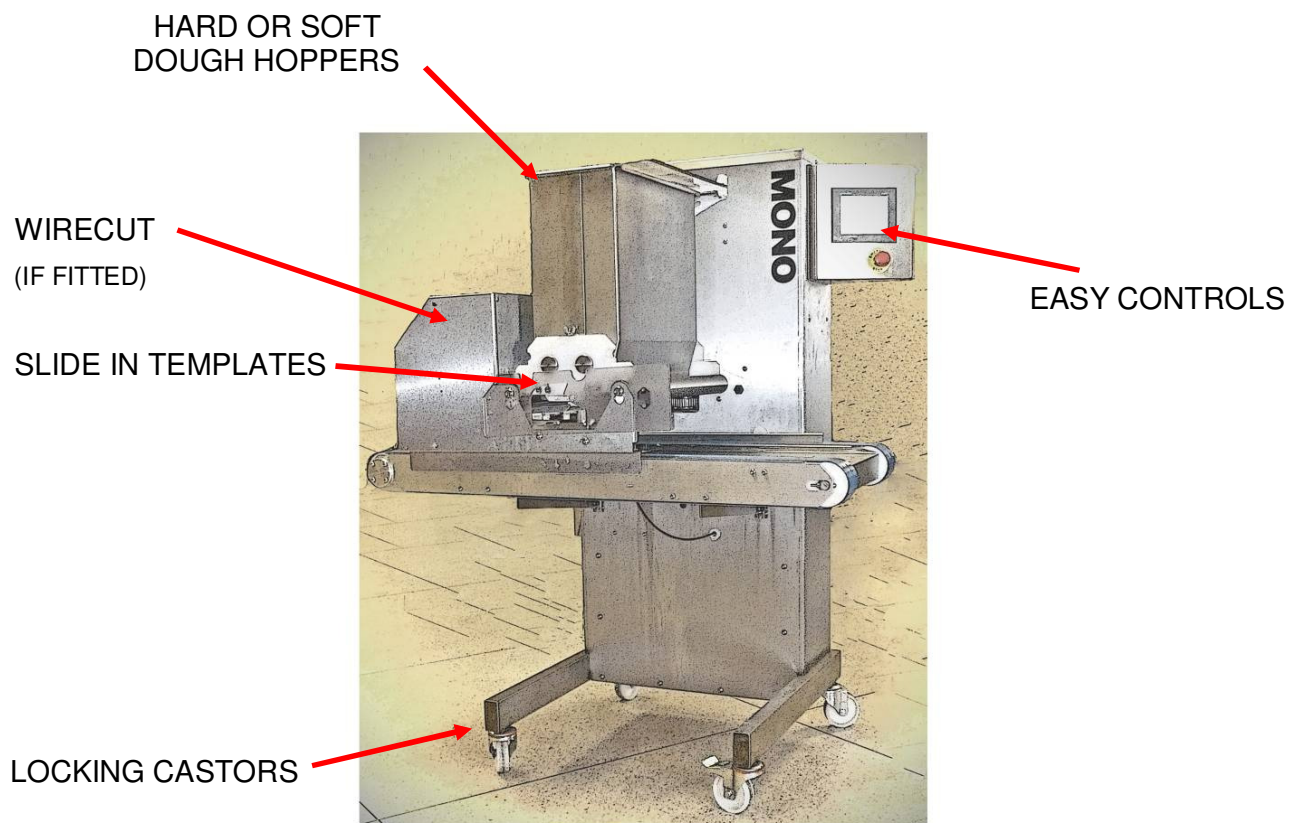

As it is our policy to improve our machines continuously,
we reserve the right to change specifications without prior notice

MODELS ARE AVAILABLE WITH OR WITHOUT WIRECUT OPTION

2.0 DIMENSIONS

Omega PLUS

MODELS ARE AVAILABLE WITH OR WITHOUT WIRECUT OPTION

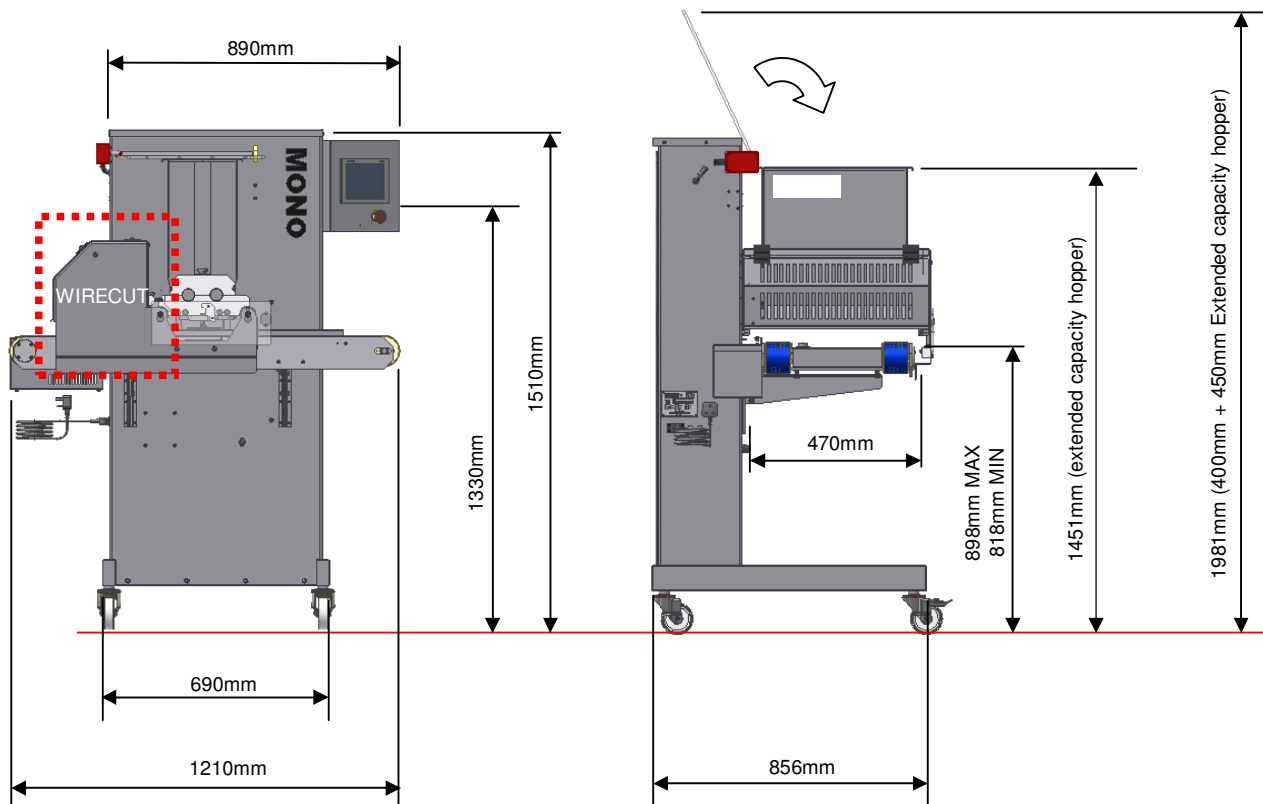

3.0 SPECIFICATIONS

Omega
PLUS

	<u>SOFT DOUGH</u>		<u>HARD DOUGH</u>	
	400	450	400	450
MODEL (Nom. hopper width (mm))				
Weight (with hopper fitted) (kg) :	196	210	216	235
Standard hopper Capacity (litre) :	20	22.5	21	24
Extended hopper Capacity (litre) :	36	41	31	35

Power: Single phase, 13A max load. Suitable for 200v, 220v, 230v, and 240v, 50-60 Hz supply.

MAX RATING 2.5kW single phase fused at 13A

Cycles per minute	= Up to 35
Min distance between trays	= 50mm
Max vertical travel	= 80mm
Max program storage	= 650
Number of languages	= 13 (additional in future)
Noise level	= Less than 85dB
Electronics	= All microprocessor controlled

NOTE:

The minimum deposit that can be made depends on several factors - recipe, mixing method, template size, nozzle size and deposit speed.

As a guide the following is the minimum that should be attempted:

Macaroons	6g,
Meringues	3g,
Choux Paste	5g,
Viennese	4g,
Sponge Drops	4g.

However, consult **Mono Equipment** if intended product falls outside the above general machine specification to determine the exact capabilities of the "Omega" with any specific product.

As it is our policy to improve our machines continuously, we reserve the right to change specifications without prior notice



- 1 **Never use a machine in a faulty condition** and always report any damage.
- 2 **Only trained engineers** may remove parts that need a tool to remove them.
- 3 Always ensure hands are dry before touching any electrical appliance (including cable, switch and plug). **NEVER move machinery by pulling on the power cords or cables.**
- 4 **Ensure that the floor area around the OMEGA is clean to avoid slipping** – especially if carrying heavy hopper and template components to and from the machine.
- 5 **All operatives must be fully trained.**
Use of the machine can prove dangerous if:
 - ❑ the machine is operated by **untrained or unskilled staff**
 - ❑ the machine is not used for its **intended purpose**
 - ❑ the machine is **not operated correctly**

All safety devices applied to the machine during manufacture and the operating instructions in this manual are required to operate this machine safely. The owner and the operator are responsible for operating this machine safely.
- 6 People undergoing training on the machine must be under **direct supervision**.
- 7 **Do not operate the machine with any panels or guards removed.**
- 8 **No loose clothing or jewellery** should be worn while operating the machine.
- 9 **Switch off power** at the mains isolator when machine is not in use and **before carrying out any cleaning or maintenance.**

10 The bakery manager or the bakery supervisor should carry out **daily safety checks** on the machine.

11 Do not operate machine without hopper **template and guard fitted correctly**.

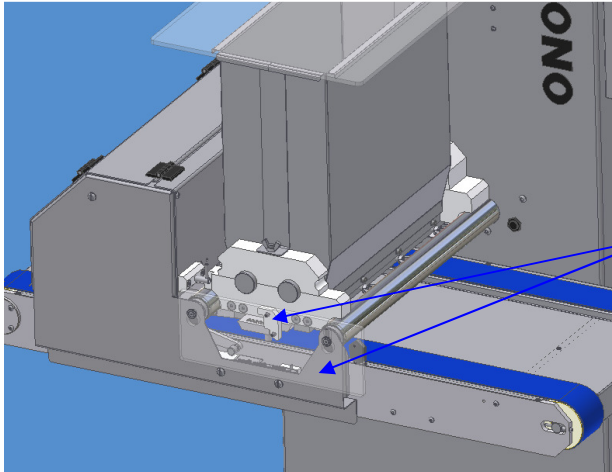

(11) HOPPER TEMPLATE AND
GUARD FITTED

12 Due to the essential requirement for handling heavy components during cleaning, it is recommended that **protective footwear** be worn when carrying out such procedures.

**ALL CLEANING AND MAINTENANCE OPERATIONS MUST
BE MADE WITH THE MACHINE DISCONNECTED FROM
THE POWER SUPPLY.**

5.0 INSTALLATION

Omega
PLUS

- 1 Ensure that the depositor is connected to correct electric supply, as specified on the serial number plate on the side of the machine.
- 2 Ensure that the correct fuse rating is fitted in the electrical supply

6.0 ISOLATION

▲ IN AN EMERGENCY, SWITCH OFF AT THE ELECTRICAL MAINS WALL ISOLATOR, OR PUSH THE EMERGENCY STOP BUTTON.

To release the emergency stop button, turn clockwise.



STOP BUTTON

7.0 CLEANING INSTRUCTIONS

NOTE:



- Cleaning must be carried out by fully trained personnel only.
- Isolate machine from mains supply before carrying out any cleaning.
- Do not steam clean or use a jet of water.

-Do not use any form of caustic detergent or abrasive cleaners. -

All the outer surfaces of the machine should be wiped over daily with warm soapy water.

HARD AND SOFT DOUGH HOPPERS BETWEEN PRODUCT MIX CHANGES

The feed hopper, pump assembly, template, nozzles etc. should be removed from the machine and dismantled for thorough cleaning between product mix changes.

1. Open top safety guard and remove excess mixture remaining in the feed hopper.
2. Lift off front see-through safety cover.

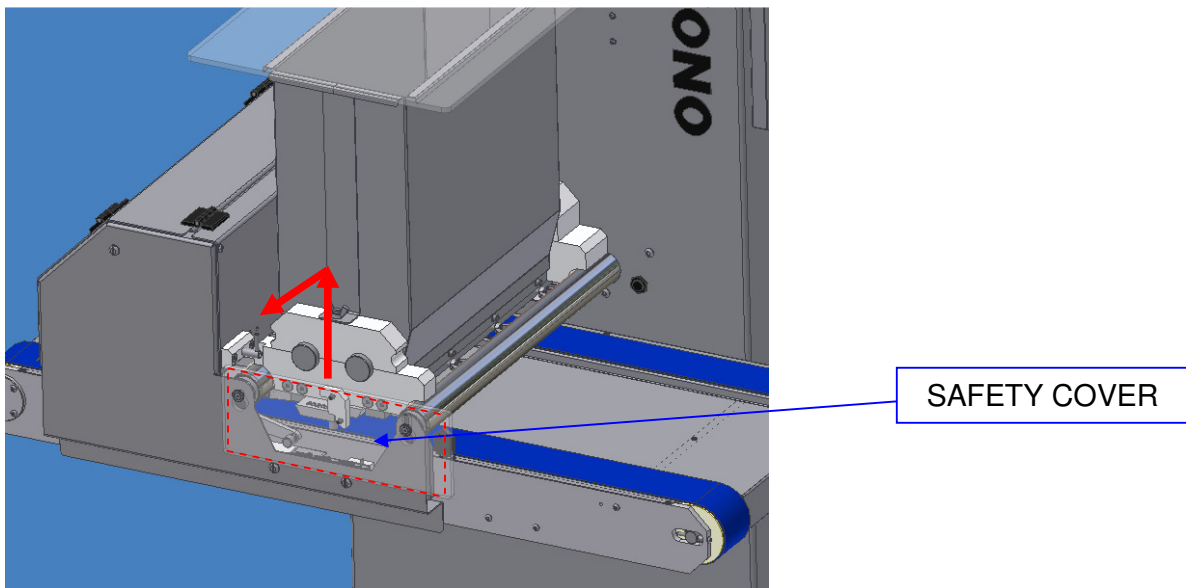

3. Slacken template clamp strip nuts or thumbscrews (depending on type of hopper)
Remove fitted template from pump assembly by sliding out to avoid subsequent damage.

NOTE.

Thumbscrews only need to be released slightly to allow the template to slide away from the pump assembly. If loosened too much, the template will have to be supported.

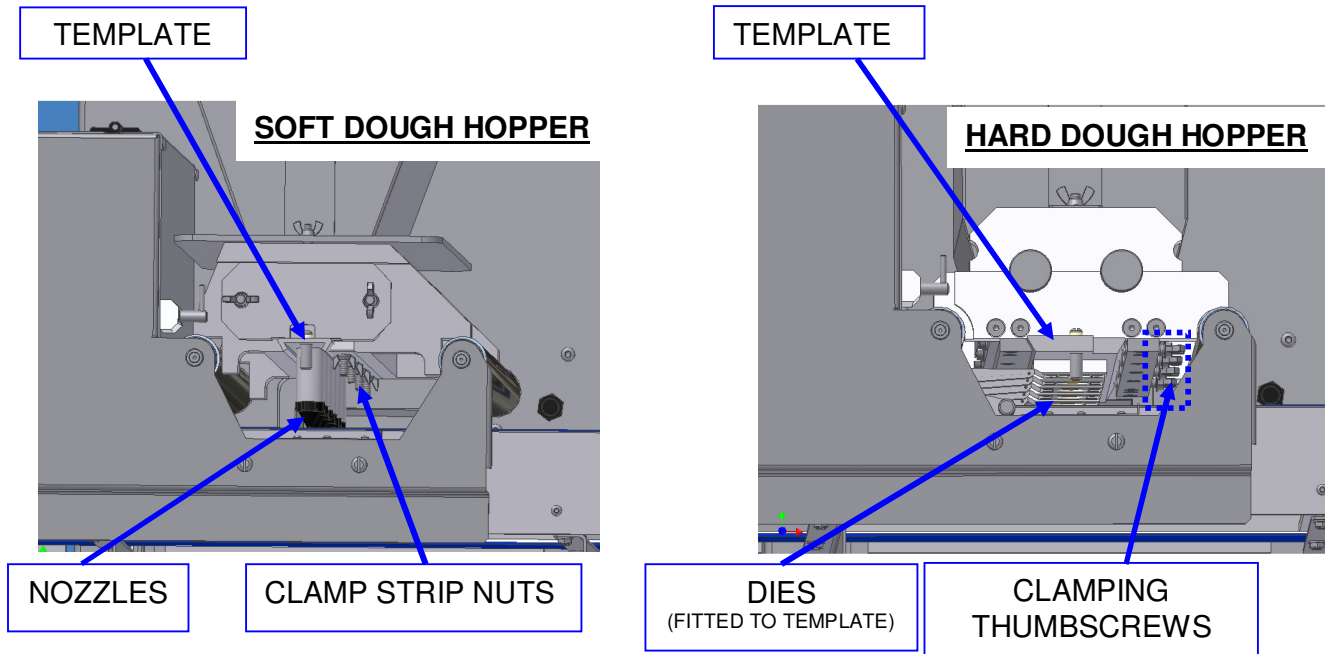

- 4 To reduce weight and bulk, separate and remove empty feed hopper from pump assembly, whilst still on the machine, by unscrewing the wing nuts.

To gain access to the inner wing nut, slide the complete hopper away from the machine body slightly (keep on support bars) - this will also disengage the pump assembly from the drive shaft.

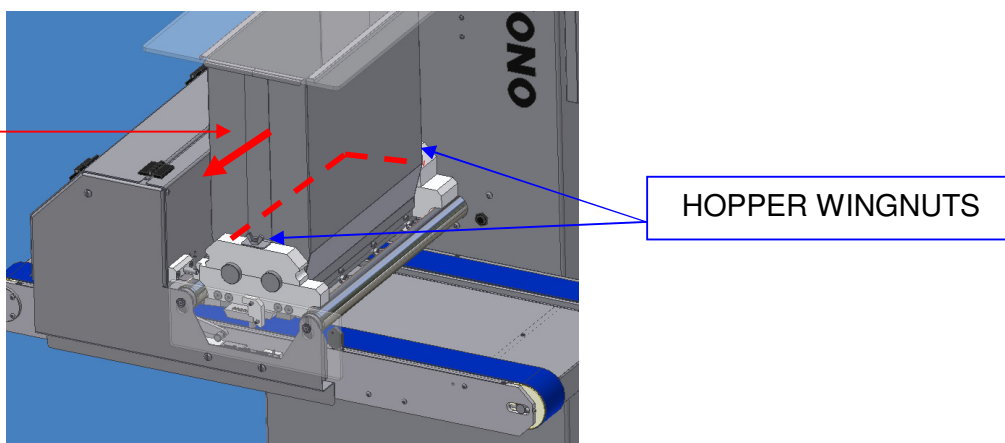

Ensure that the nuts are placed where they will not be lost.

SOFT DOUGH HOPPER

Omega
PLUS



CAUTION:

The feed hopper and pump assembly exceeds 25kg and will need to be lifted off by two people, or dismantled into smaller components while still on the machine.

Take care to avoid damage to the sealing surface of the feed hopper during removal, cleaning, assembly and storage.

1. After removing the feed hopper, check condition of feed hopper seal.
2. Unscrew the end cap retaining nuts from the accessible side of the pump assembly.
[Ensure that the nuts are placed where they will not be lost.]

FEED HOPPER
SEALING SURFACE

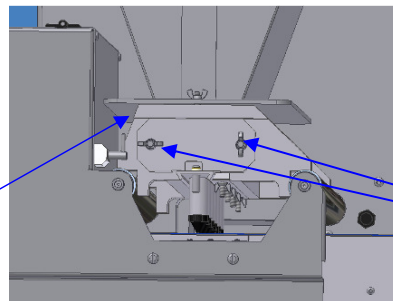

ENDCAP NUTS

3. Withdraw the end-cap with the pump gears.

Ensure that the 'O' sealing ring on the inside of the end cap is not damaged during cleaning.

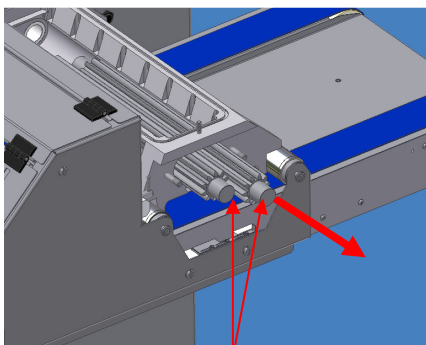

PUMP GEARS
REMOVE WITH END CAP
(NOT SHOWN)

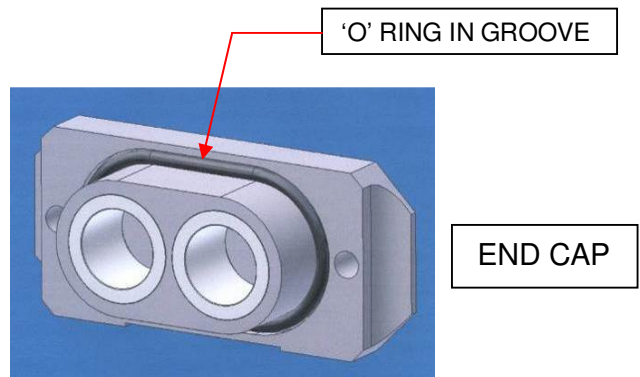

'O' RING IN GROOVE

END CAP

4. Remove remainder of pump assembly from the machine and remove remaining end-cap to fully dismantle pump assembly components for cleaning.

HARD DOUGH HOPPER



CAUTION:

The feed hopper and pump assembly exceeds 25kg and will need to be lifted off by two people, or dismantled into smaller components while still on the machine.

To reduce weight and bulk, separate and remove empty feed hopper from pump assembly, whilst still on the machine, by unscrewing the wing nuts.

(Ensure that the nuts are placed where they will not be lost.)

The pump assembly will now be lighter and more easily removed.

1. Lift off both upper plastic end-caps.
2. Remove both gears from the assembly, one at a time, by lifting vertically.
3. Remove remainder of pump assembly from the machine for cleaning.

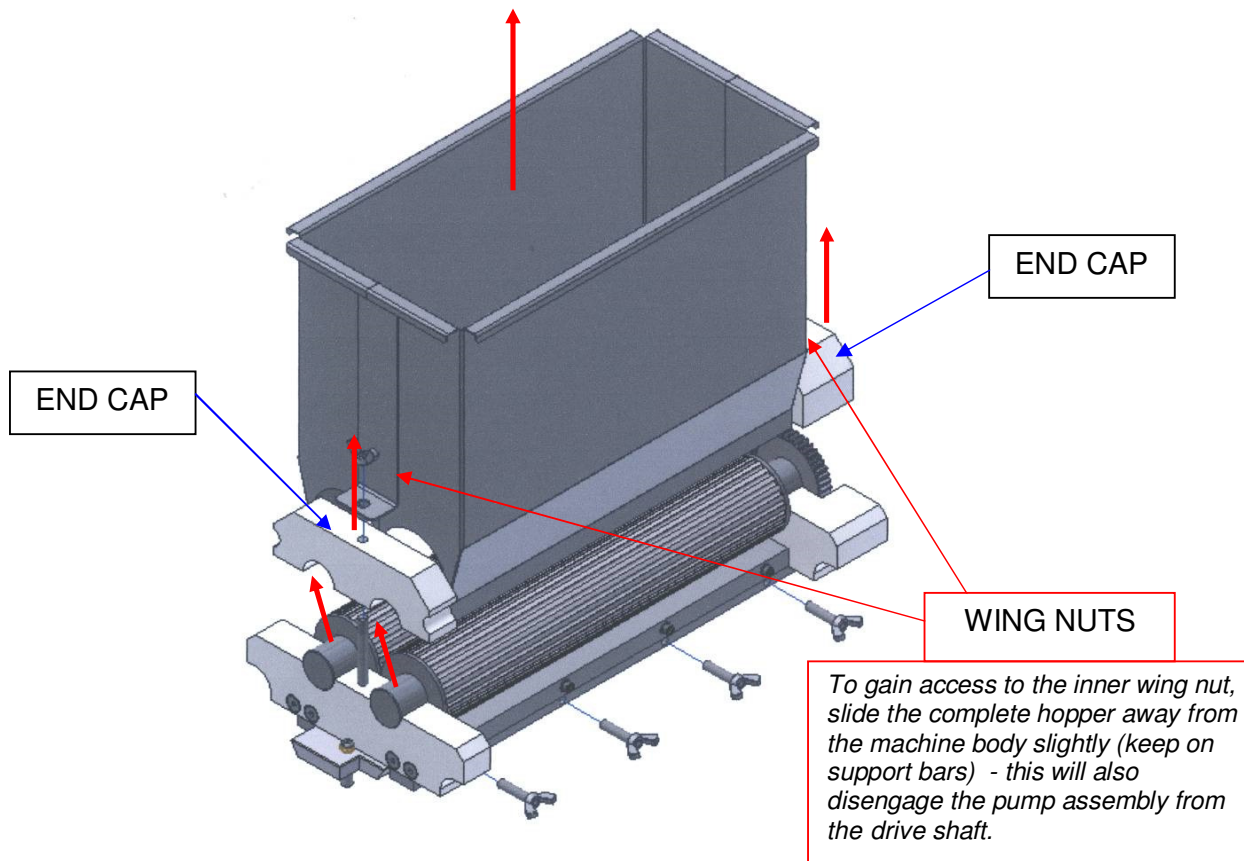

NOTE:

Use only warm soapy water to clean these parts. They should be rinsed and thoroughly dried before re-assembly.

The greatest care must be taken not to drop any parts.



Do not leave any components in the hopper.



8.0 OPERATING CONDITIONS

Omega
PLUS

To obtain the best product results and consistent operation,

- ✓ Make sure the depositor is used on a **level floor**.
- ✓ Ensure **flat trays** of consistent length, width, material and edge dimensions are used.
- ✓ Ensure **undamaged nozzles and templates** are used.
- ✓ Keep the machine **clean**.



9.0 PREPARING FOR OPERATION

Omega
PLUS

The use of templates and/or accessories not produced or supplied by MONO Equipment will invalidate the machine's warranty

- 1 Select template and nozzles (and finger frame, if wirecut is to be used) and fit as section 9a & 9b (following pages). Fill hopper with mix and close hopper cover.

It is recommended that when heavy mixes are used, the inside of the hopper should be coated with vegetable oil; for lighter mixes such as meringue, dampen with water. The oil or water will help the mix to settle down the hopper walls and prevent air being sucked in.

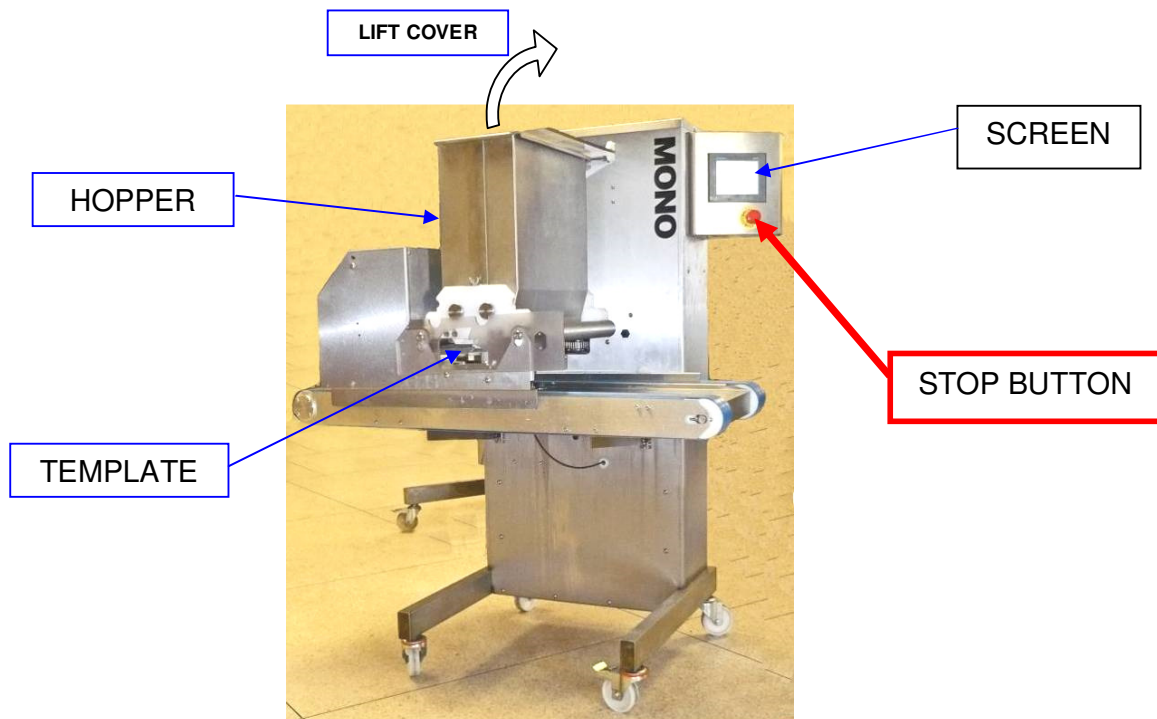

- 2 Connect power cable to electrical supply.
Make sure stop button is in released position (turn clockwise if required).
- 3 Select an existing program or create a new program through the on-screen menus.
(see section 10 operation)
- 4 The machine is now ready for operation.

9a FITTING THE HOPPER

CAUTION SHOULD BE TAKEN WHEN FITTING THE HOPPER AND PUMP ASSEMBLY, AS WEIGHT EXCEEDS 25kgs ON SOME MODELS
 It will need to be lifted on by two people, or dismantled into smaller components before fitting on the machine.
MAKE SURE THE FLOOR AREA AROUND THE MACHINE IS CLEAN

To reduce weight and bulk, fit the complete hopper assembly in two stages - first the pump assembly onto the support bars, then the feed hopper body onto the pump assembly.

- 1 By hand, align pump assembly drive gear roller with drive shaft on machine.
- 2 Fit hopper to pump assembly and secure with wing nuts.
- 3 Slide hopper on support bars until fully up against machine.

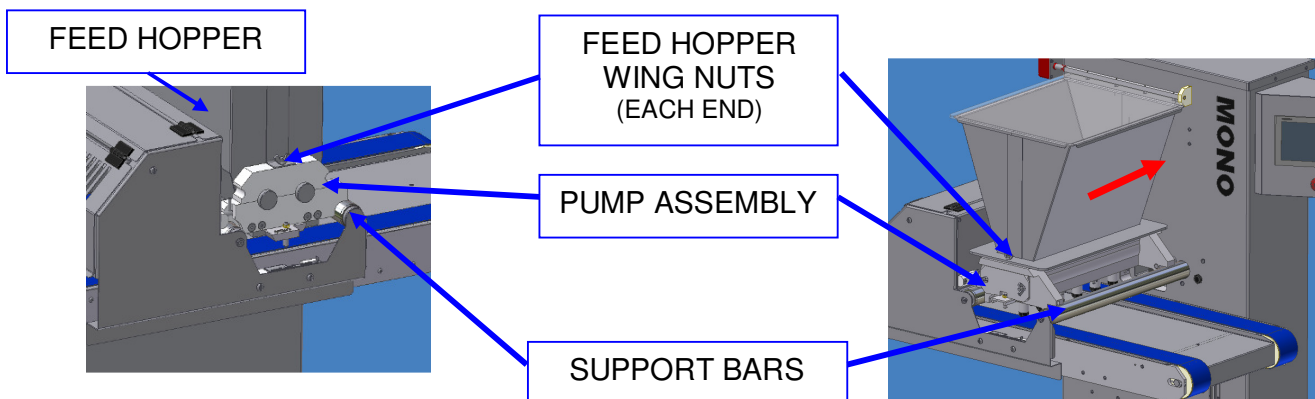

HARD DOUGH

SOFT DOUGH

- 4 After the hopper is fitted, the safety cover **MUST BE** replaced with the reflector facing towards the machine body.

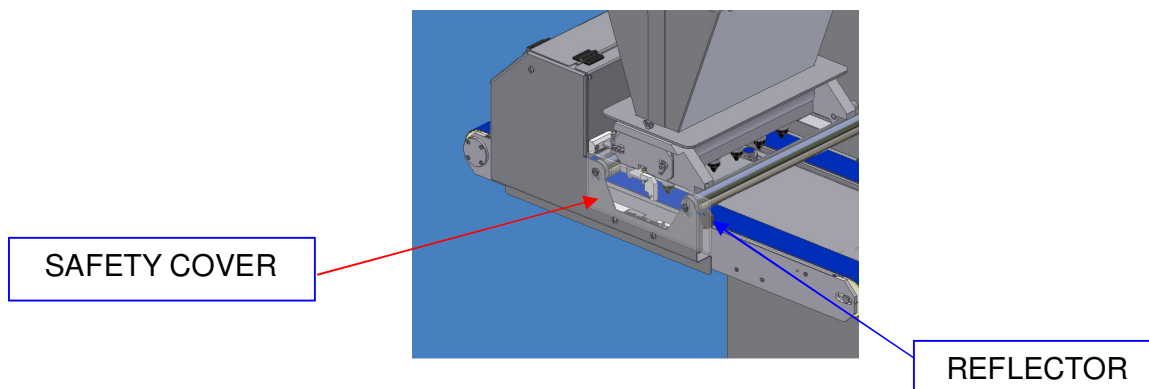

DO NOT OPERATE MACHINE WITHOUT TEMPLATE FITTED

9b FITTING A TEMPLATE

- **Soft dough**

Non-rotary templates can be fitted with nozzles. This requires screwing the nozzles into the threaded holes provided.

Rotary templates can have plastic nozzles screwed into nozzle holders (straight or offset).

OR

Metal nozzles secured in place by a separate nut.

- 1 Select template and nozzles required.
(Nozzles are not required for sheeting, staggered or stub templates)
- 2 Attach nozzles to template body:

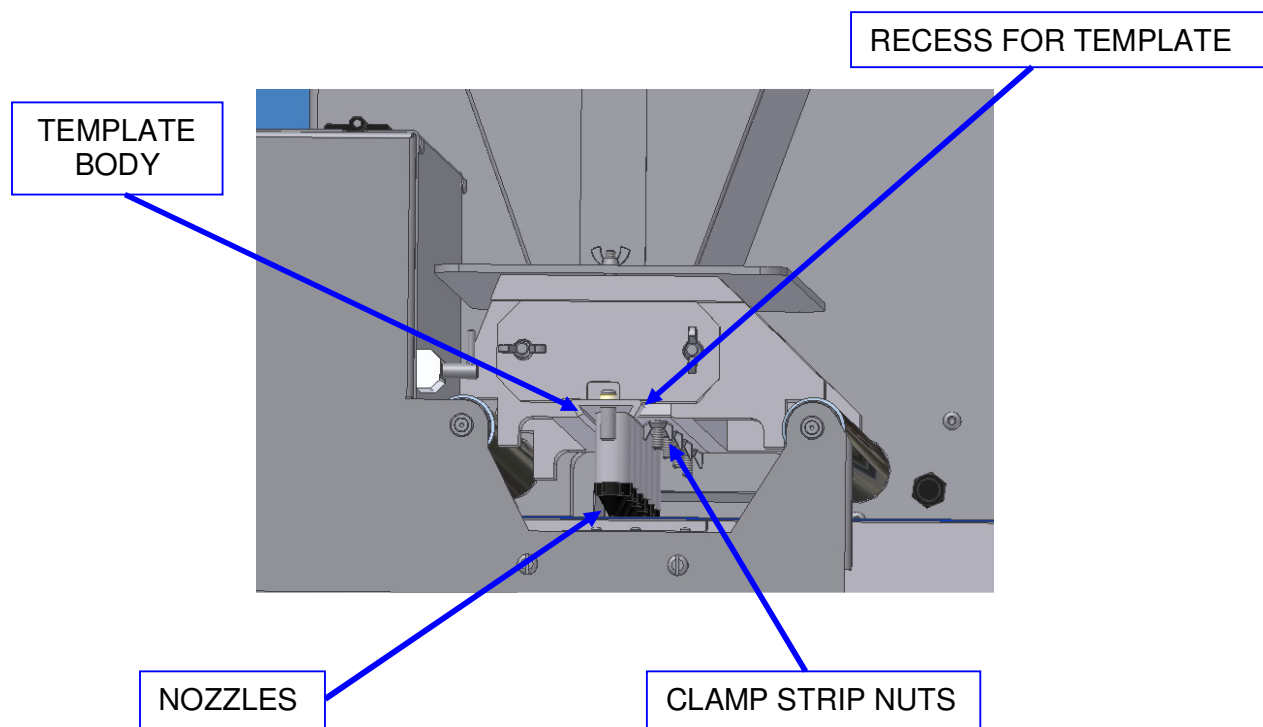

- 3 Slide the template into the matching recess at the base of the pump assembly until the stop is in position.
- 4 Tighten the nuts on the clamp strip (on underside of pump assembly) to secure template.

NOTE. *If the nuts are not securely tightened, leakage of mix will occur, affecting deposit weights.*

DO NOT OPERATE MACHINE WITHOUT TEMPLATE FITTED

BEFORE USING STRAIGHT & OFFSET NOZZLE HOLDERS **“O” RINGS MUST BE FITTED**

Nozzle holders provide the means of attaching standard plastic nozzles to the soft dough rotary templates and the sealing rings need to be fitted before using and may need replacing occasionally to ensure correct operation.

“O” RING PART NUMBER = A900-12-010 (SUPPLIED IN BAGS OF 20)

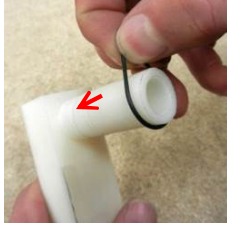

LOOP FIRST RING OVER END



SLIDE RING DOWN TO GROOVE



FIRST RING IN CORRECT POSITION

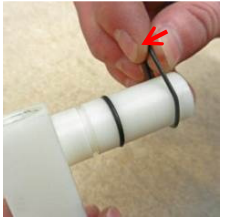

LOOP SECOND RING OVER END



SLIDE RING DOWN TO SECOND GROOVE,
PASSING OVER FIRST RING



SECOND RING IN CORRECT POSITION

• Hard dough

Non-rotary templates that can be fitted with nozzles require them to be secured in place with a separate nut. Nozzles are not required for sheeting or wirecut templates.

Rotary templates require nozzles to be secured in place with a separate nut.

- 1 Select wirecut template or template and nozzles required.
- 2 Attach nozzles (if required) to template body using special nut:
- 3 Slide template into position and hand-tighten thumbscrews.

NOTE.

Thumbscrews only need to be released slightly to allow the template to slide away from the pump assembly. If loosened too much the template will have to be supported while the screws are tightened.

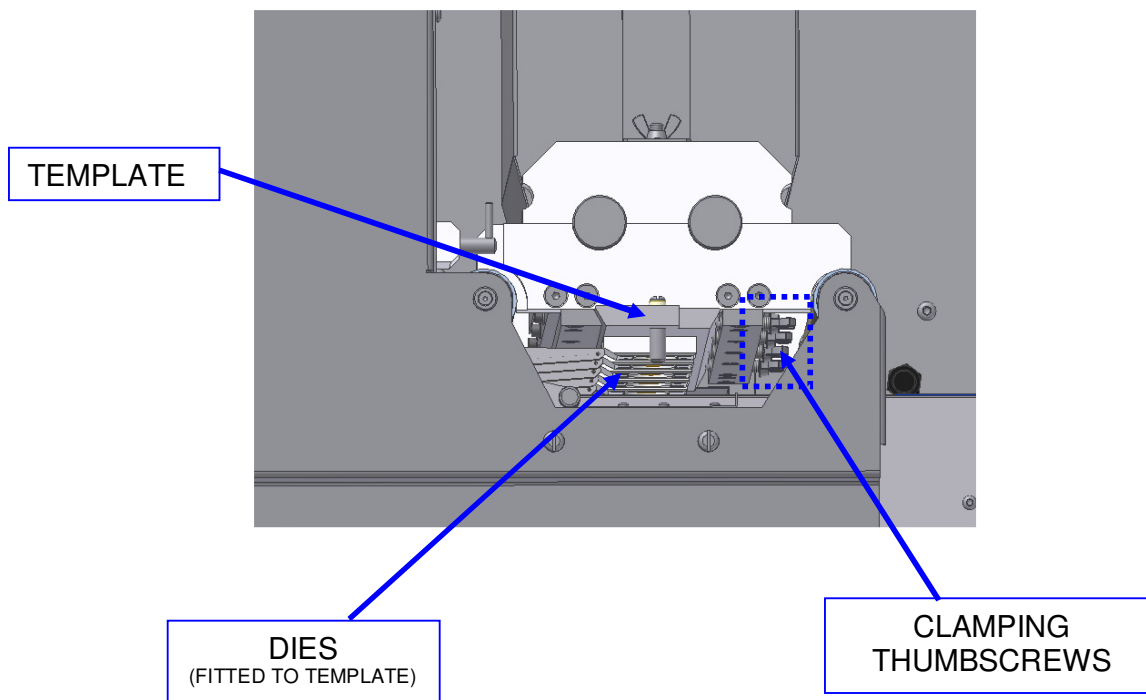

DO NOT OPERATE MACHINE WITHOUT TEMPLATE FITTED

IF WIRECUT FITTED

FITTING WIRECUT FINGERS

1. Select wirecut fingers that suit the chosen template to be used.i.e. the correct number to match the number of dies across template.
2. Remove drop arm pins and insert finger frame into arms. Ensure that the follower arm roller is positioned on the cam track.

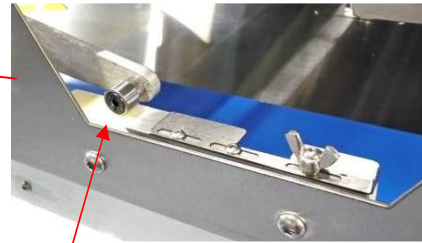
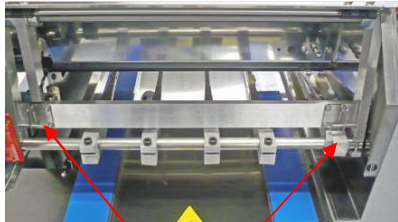

FOLLOWER ARM ROLLER

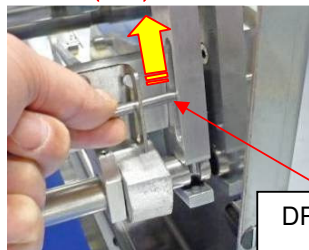

DROP ARM PINS

3. Replace drop arm pins.
4. Disconnect motor release knob and push fingers forward in order to line up the wire with the dies.



MOTOR RELEASE KNOB

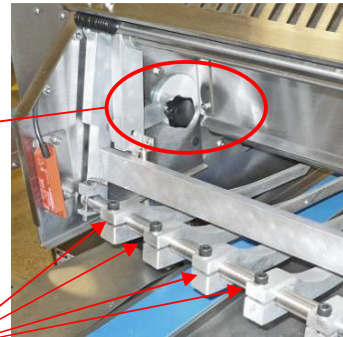

FINGER ADJUSTING BOLTS

5. Adjust individual finger bolts to raise the wire to touch the bottom surface of the dies used in the template.

OR

Adjust the spring loaded screw to raise or lower all fingers at the same time.



SPRING LOADED ADJUSTMENT SCREW

IF WIRECUT FITTED

REPLACING BROKEN WIRE

MAKE SURE THAT ALL PIECES OF WIRE HAVE BEEN FOUND BEFORE OPERATING MACHINE AFTER A WIRE REPLACEMENT.

1. Remove fingers from the machine.
2. Remove broken wire
3. Feed new wire round screw between washers and tighten screw.
4. Feed the wire through the eyehole in the end of each finger.
5. Feed new wire round other screw between washers. Pull tight and tighten screw. (wire should be like a guitar string).
6. Replace the fingers back in the machine and check set up and operation.

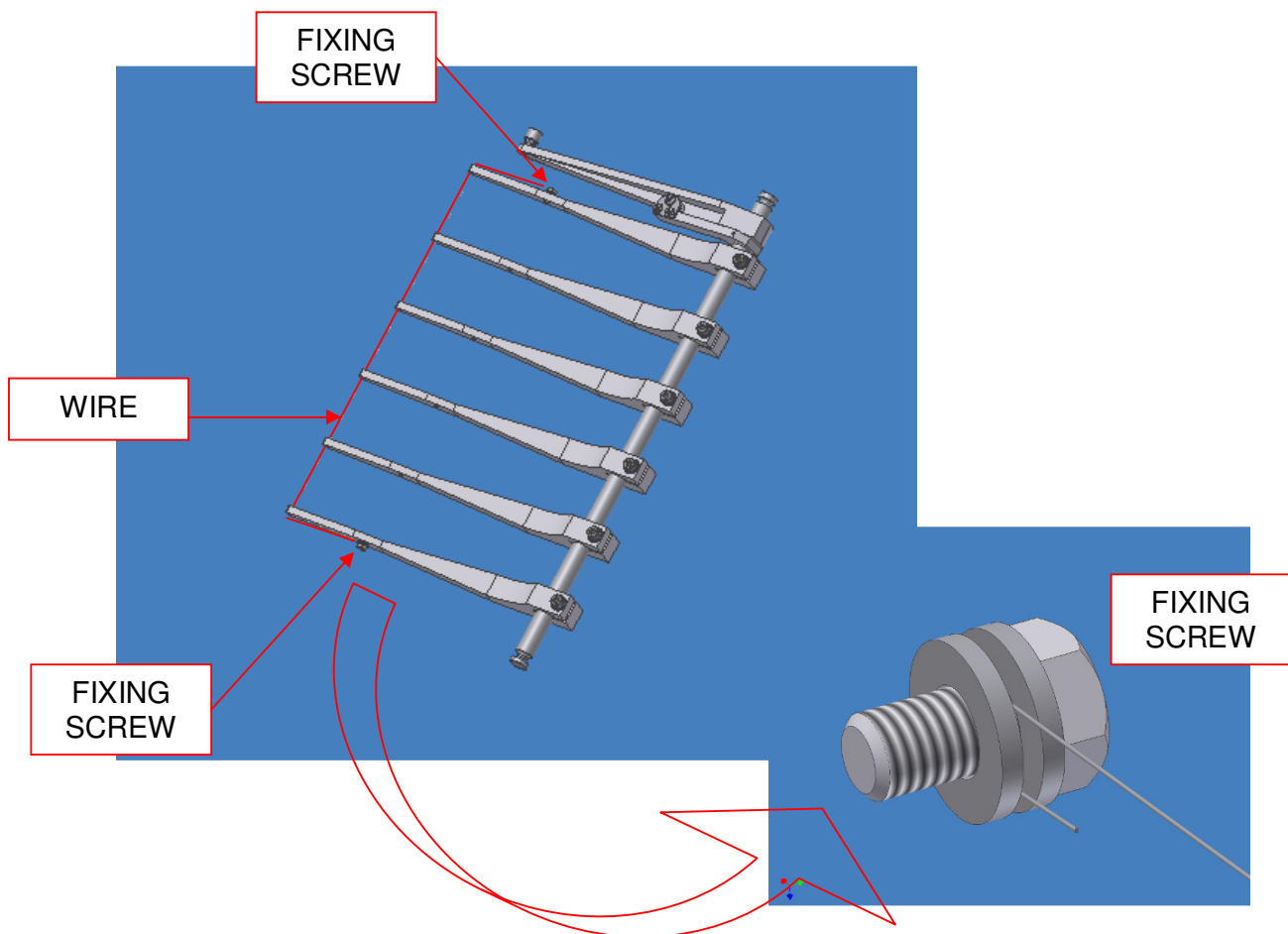

10.0 'OMEGA PLUS' OPERATION

Omega PLUS

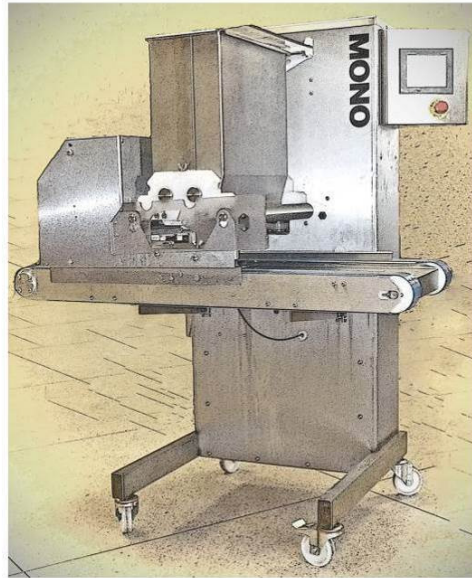

Software Information



OMEGA TOUCH

HMI V1.0

TLCC V0.000

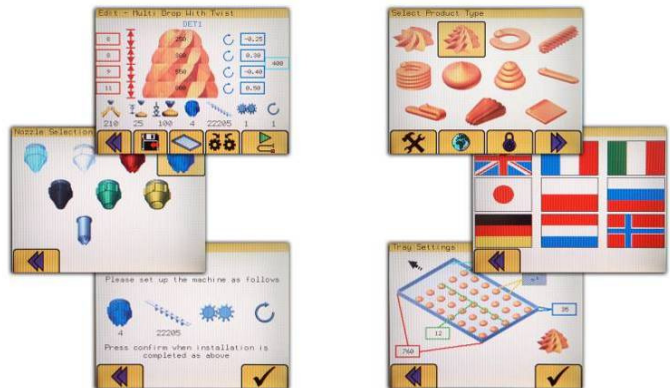

ALL OPERATIONS ARE ACTIVATED BY TOUCHING AREAS ON THE SCREEN WITH A FINGER. DO NOT USE EXCESSIVE FORCE OR HARD OBJECTS AS THIS WILL INVALIDATE MACHINE WARRANTY.

OPERATING KEY

FOR FOLLOWING INSTRUCTIONS

BLUE = OPERATION FOLLOW BLUE ARROWS AND BOXES TO OPERATE THE DEPOSITOR WITH ALREADY SAVED PROGRAMS

RED = CHANGE SETTINGS FOLLOW RED ARROWS AND BOXES TO CHANGE SETTINGS AND CREATE NEW PROGRAMS

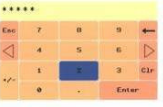
 **= KEYBOARD ENTRY REQUIRED** WHEN KEYBOARD APPEARS, A CODE MUST BE ENTERED BY TOUCHING THE NUMBERS IN THE CORRECT ORDER

IF A GREY BOX IS SHOWN IN THE BUTTON DESCRIPTION
 e.g. 7 GO TO THE CORRESPONDING PAGE FURTHER
 ON IN THE INSTRUCTIONS.

(MARKED IN TOP RIGHT HAND CORNER OF EACH PAGE)

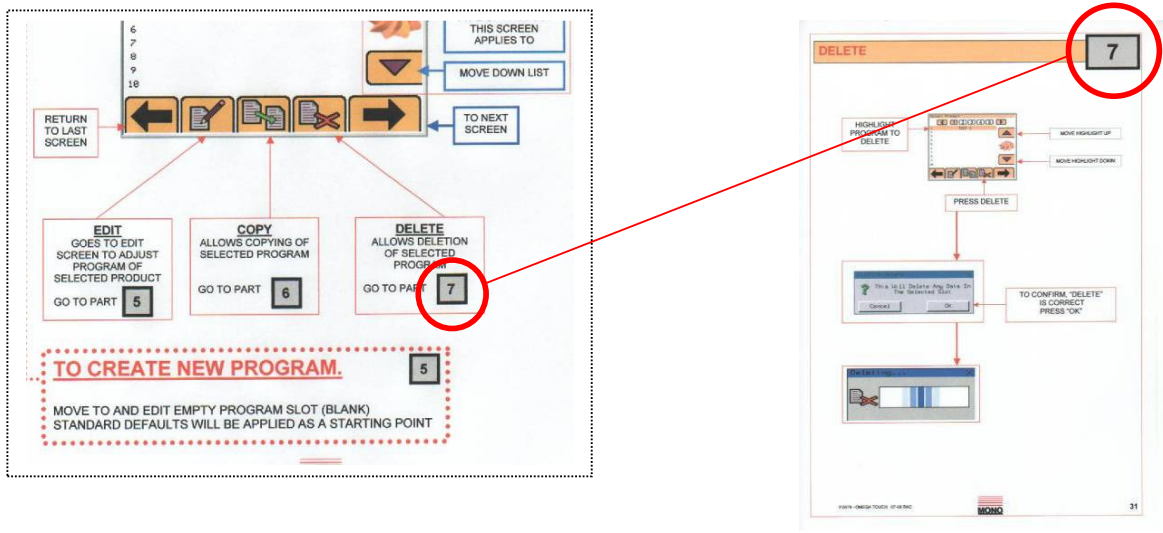

SELECT PRODUCT TYPE

SELECT PRODUCT TO DEPOSIT OR TO CREATE A NEW PROGRAM

1

ALL OPERATIONS ARE ACTIVATED BY TOUCHING AREAS ON THE SCREEN WITH A FINGER.
DO NOT USE EXCESSIVE FORCE OR HARD OBJECTS AS THIS WILL INVALIDATE MACHINE WARRANTY.

TOUCH THE SCREEN FOR THE TYPE OF PRODUCT REQUIRED THEN → TO MOVE TO THE NEXT SCREEN

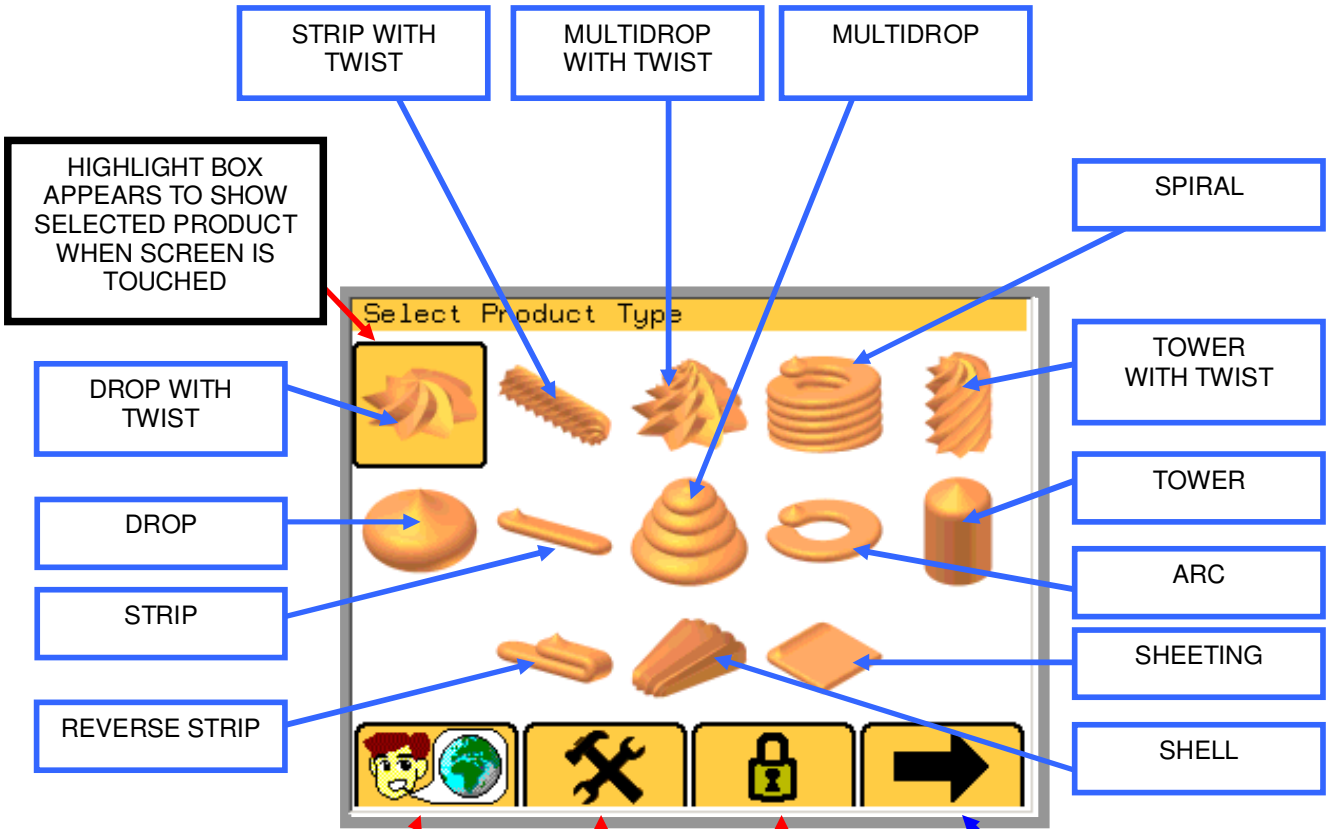

THESE BUTTONS CONTROL CHANGES TO THE MACHINE

- CHOOSE LANGUAGE**: A screen showing various national flags and a left-pointing arrow button. A label "BACK TO THIS SCREEN" points to the arrow button.
- MACHINE SETUP**: A screen with a numeric keypad and function keys.
- PRODUCT EDITING**: A screen with "COPYING" and "DELETING" options.

PASSWORDS ARE REQUIRED FOR THESE FUNCTIONS. SEE PART 8

SELECT SAVED PRODUCT TYPE

OR CHOOSE EMPTY SLOT TO CREATE A NEW PROGRAM

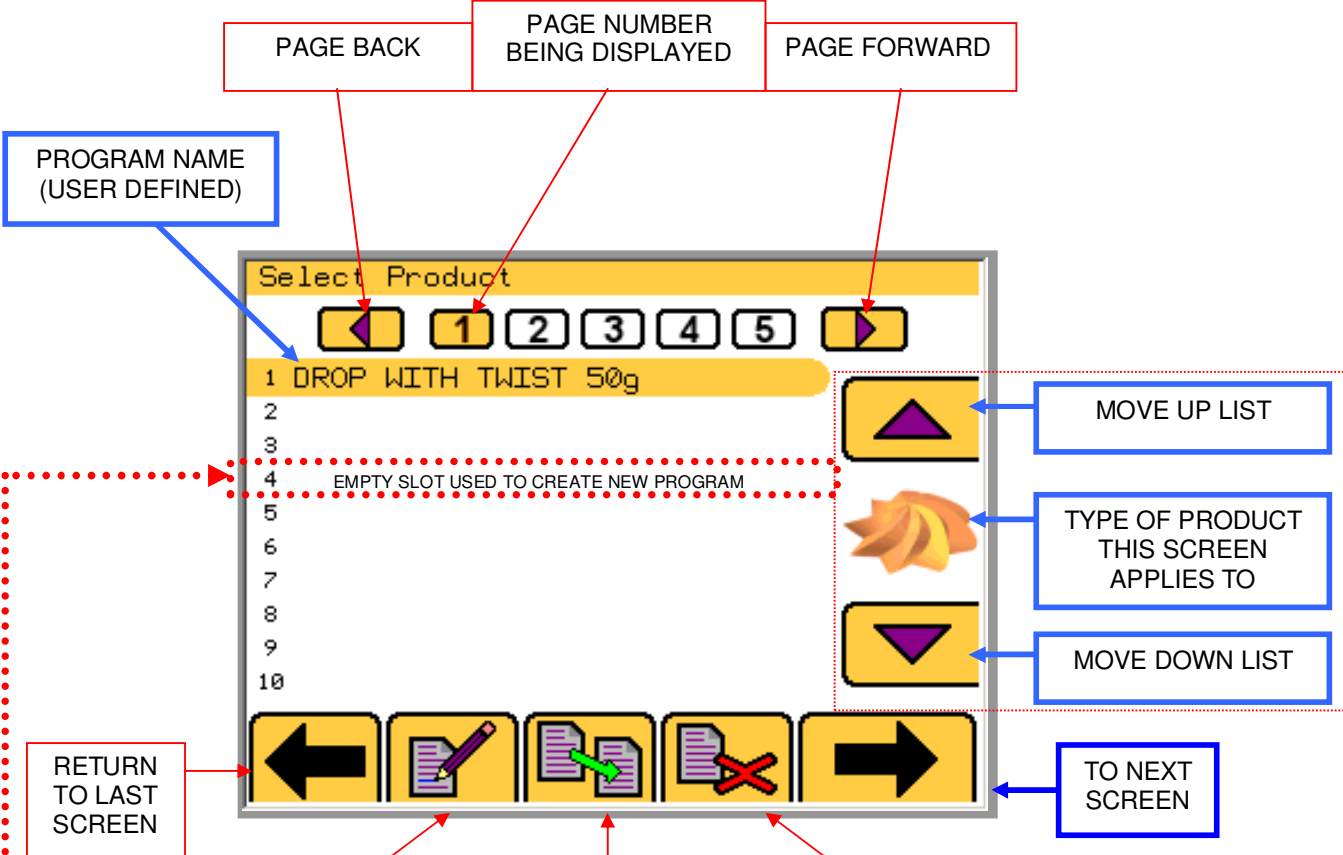

EDIT
GOES TO EDIT SCREEN TO ADJUST PROGRAM OF SELECTED PRODUCT
GO TO PART **5**

COPY
ALLOWS COPYING OF SELECTED PROGRAM
GO TO PART **6**

DELETE
ALLOWS DELETION OF SELECTED PROGRAM
GO TO PART **7**

TO CREATE NEW PROGRAM. **5**

MOVE TO AND EDIT EMPTY PROGRAM SLOT (BLANK)
STANDARD DEFAULTS WILL BE APPLIED AS A STARTING POINT

CONFIRM SETUP OF MACHINE

3

MACHINE MUST BE SET AS SHOWN ON THE SCREEN.
THEN PRESS CONFIRM BUTTON.

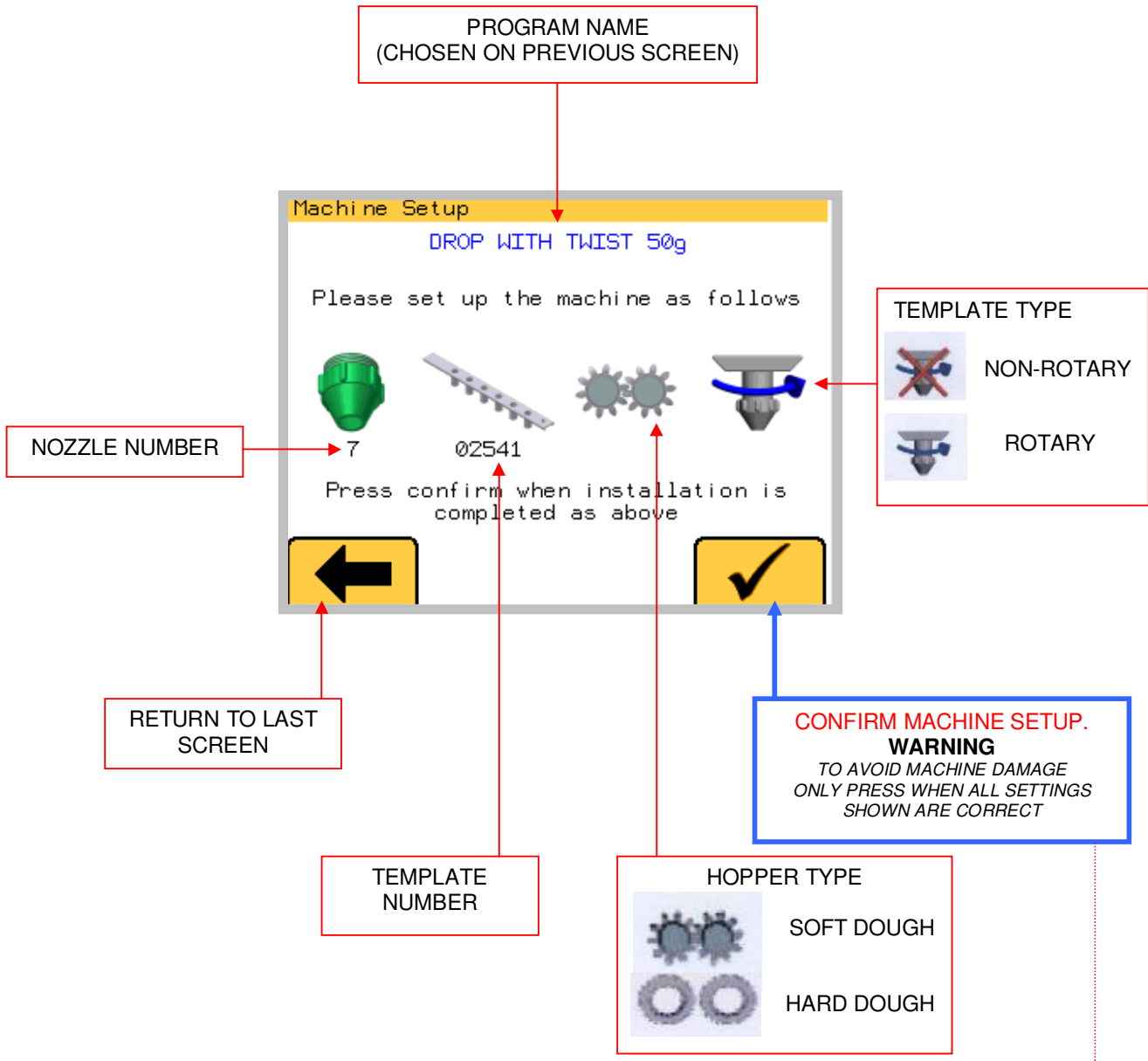

TO AVOID MACHINE DAMAGE
ONLY PRESS CONFIRM BUTTON WHEN ALL PARTS ATTACHED TO THE MACHINE
ARE AS SHOWN ON THE SCREEN

MACHINE IS SET AS SHOWN ON THE SCREEN.
THIS SCREEN CONTROLS THE ACTIONS REQUIRED BY THE OPERATOR.

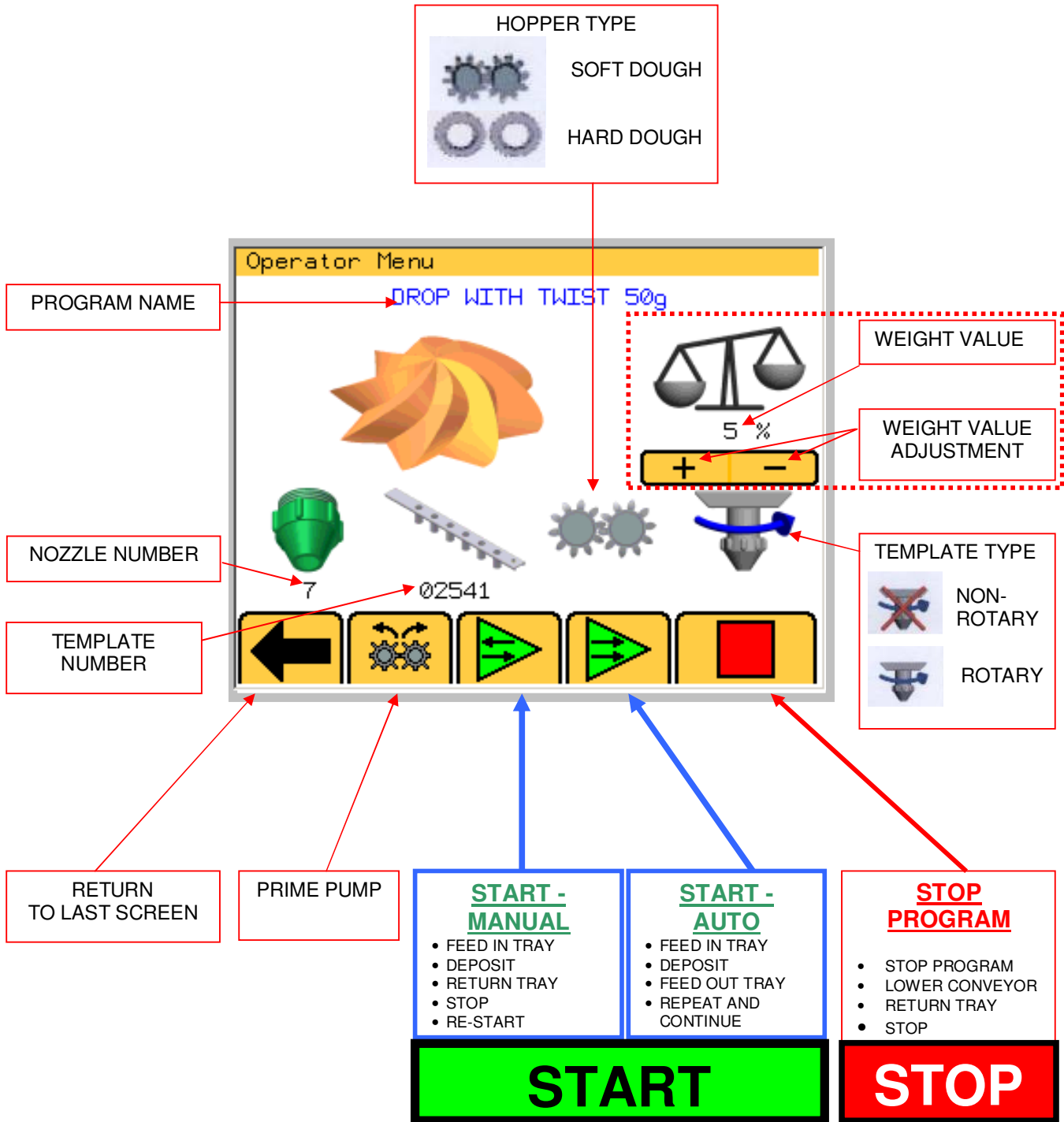

EDIT AND SAVE SCREEN

5

**EXAMPLE:
DROP WITH
TWIST**

PROGRAM NAME
MUST BE ENTERED TO
ALLOW PROGRAM TO SAVE

PRODUCT QUANTITY
THIS IS A SETTING NUMBER AND
DOES NOT INDICATE A MEASURE OF
ACTUAL VOLUME

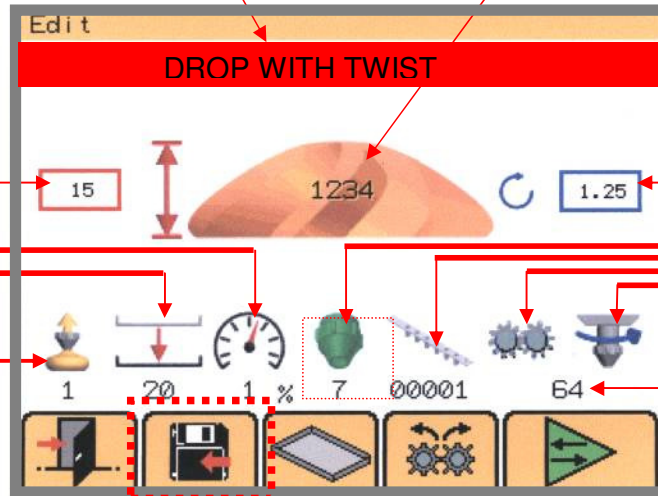

NOZZLE HEIGHT (mm)
ABOVE TRAY SURFACE

NOZZLE ROTATIONS
NUMBER OF TURNS
DURING A DEPOSIT CYCLE

EXIT THIS SCREEN



SAVE EDITS

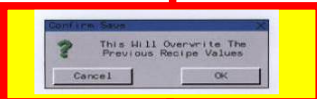

ENTER TRAY
SETUP
SCREEN

GO TO PART
5A

MAX HEIGHT FOR
HOPPER/TEMPLATE
COMBINATION

START
MANUAL MODE

PRIME PUMP
(SOFT DOUGH SHOWN)

TEMPLATE TYPE
ROTARY
NON-ROTARY

SELECT HOPPER
HARD DOUGH
SOFT DOUGH

TEMPLATE NUMBER
ENTER VIA KEYPAD
THAT APPEARS WHEN
PRESSED



NOTE

A RED BACKGROUND TO ANY
SETTING MEANS THAT THE
VALUE MUST BE
CORRECTED

SUCK BACK
QUANTITY

TABLE
JOG DISTANCE (mm)

OVERALL
MACHINE SPEED
(% OF MAXIMUM)

CHOOSE NOZZLE TYPE



**EXAMPLE:
MULTIDROP WITH
TWIST**

DEPOSIT QUANTITY FOR EACH LAYER

SETTING ERROR INDICATOR
BOXES TURN RED WHEN INCORRECT SETTING MADE

NOZZLE HEIGHT (mm) FOR EACH LAYER

NOZZLE HEIGHT (mm) FROM TRAY SURFACE

NUMBER OF TURNS FOR EACH LAYER (-VE VALUES POSSIBLE)

OTHER SETTING BUTTONS ARE THE SAME AS LAST PAGE

PRIME PUMP (HARD DOUGH SHOWN)

**EXAMPLE:
SHEETING / STRIP**

DEPOSIT QUANTITY FOR BEGINNING OF PRODUCT

DEPOSIT QUANTITY FOR LENGTH

DEPOSIT QUANTITY FOR END OF PRODUCT (-VE VALUES POSSIBLE)

NOZZLE HEIGHT ABOVE TRAY SURFACE

LENGTH (mm) OF TRAY MOVEMENT

**EXAMPLE:
"C" SHAPE
(ARC)**

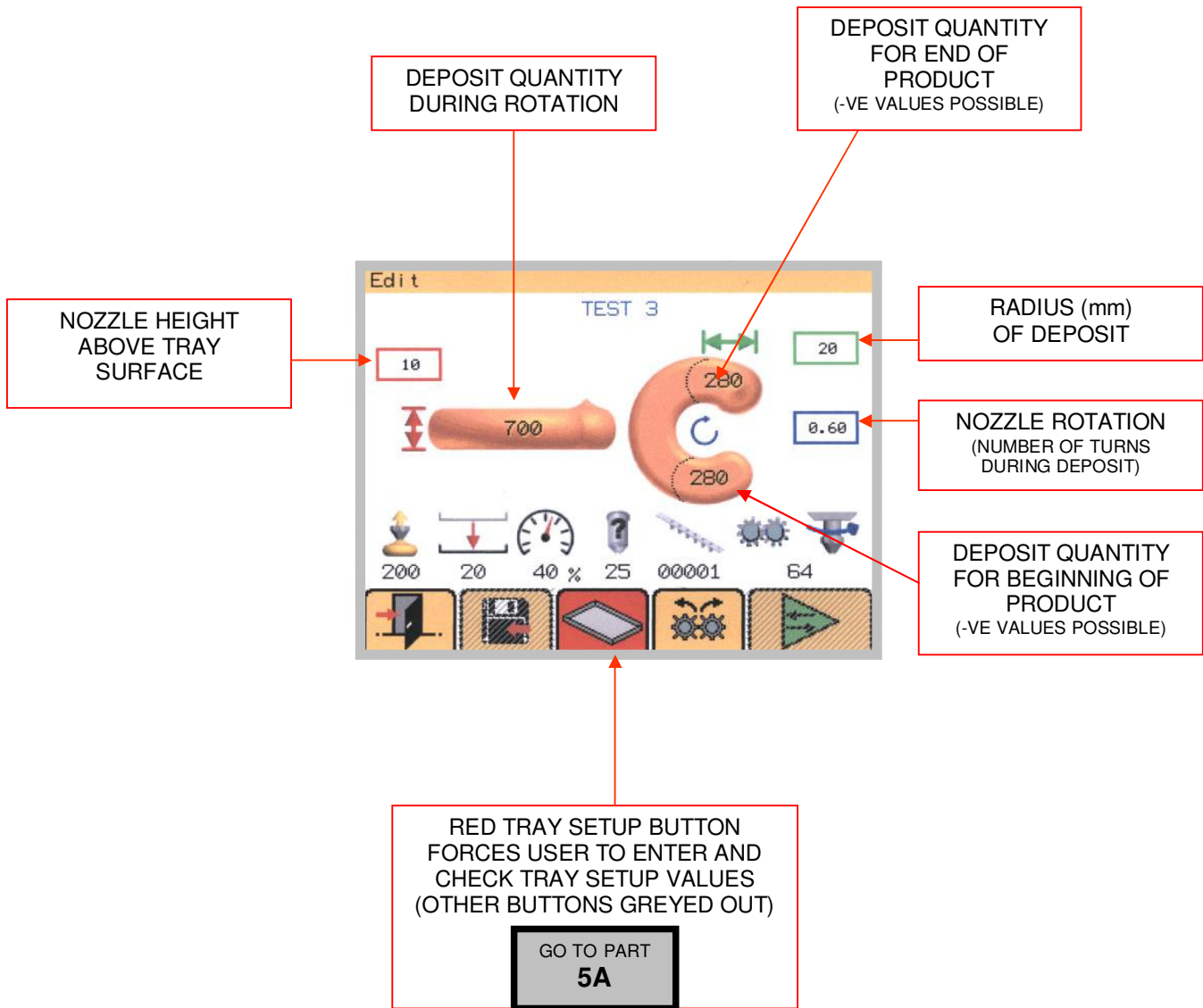

TRAY SETUP

5A

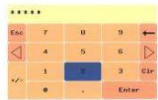

PRESS WINDOWS AND ENTER VALUES VIA KEYPAD

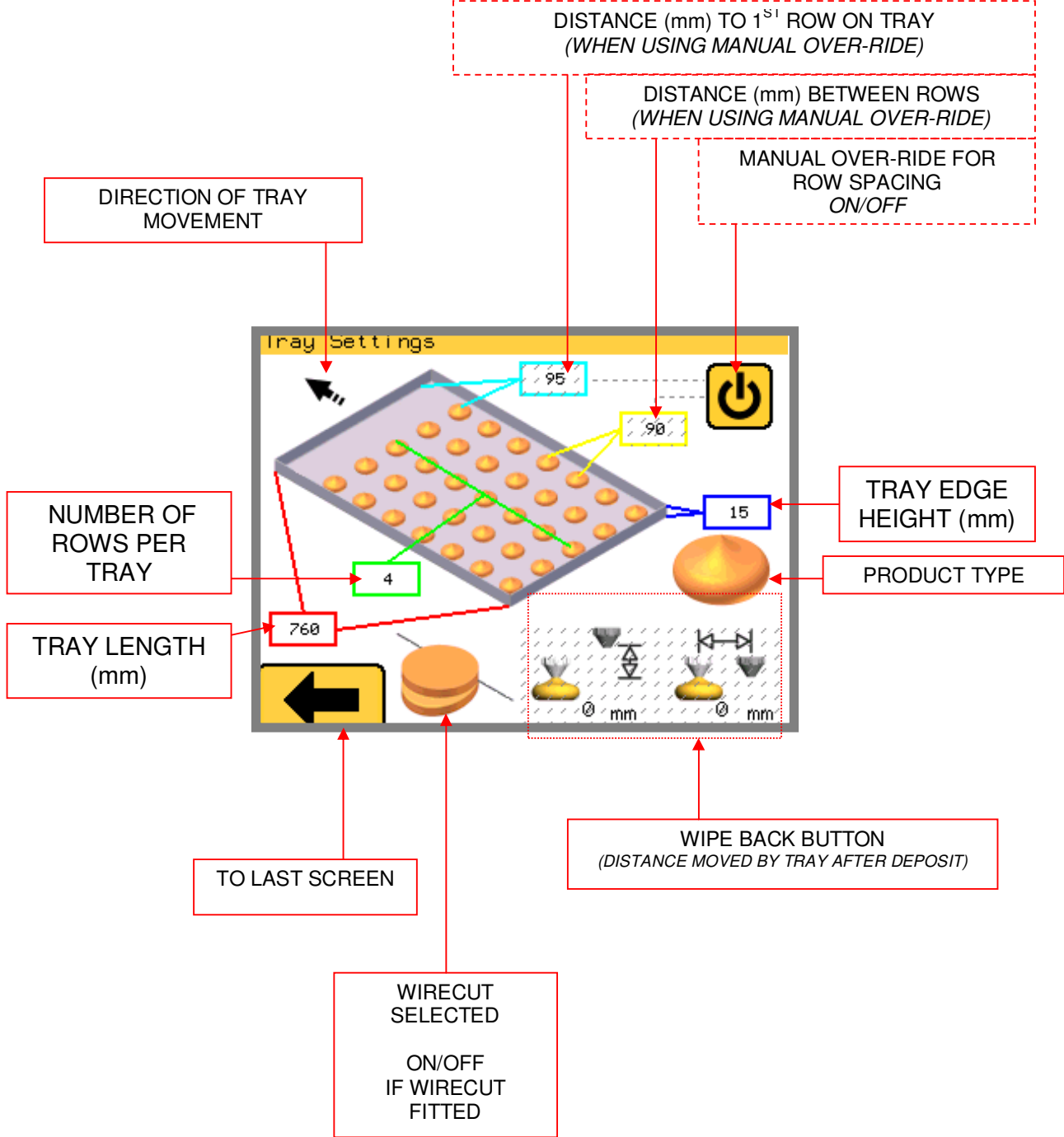

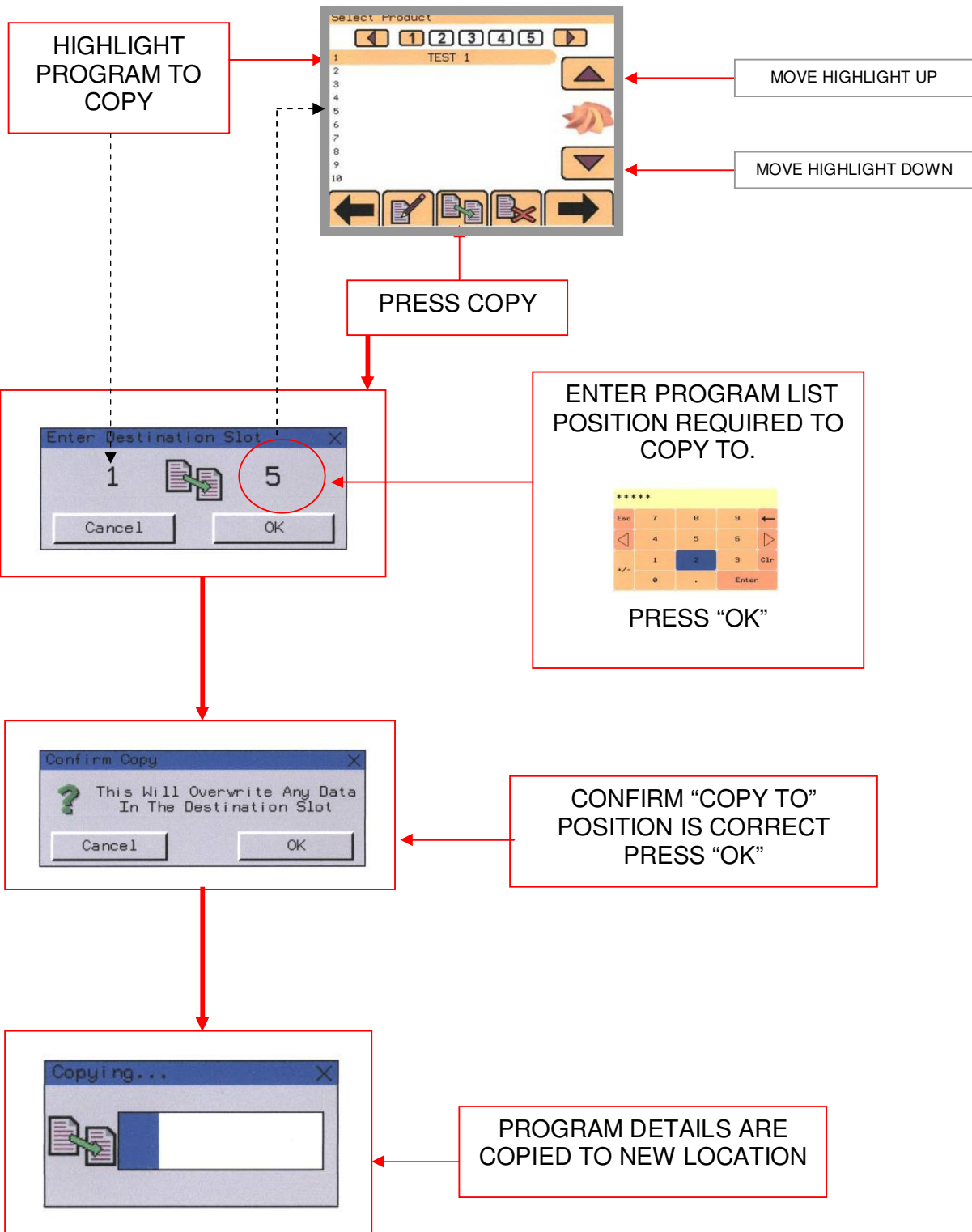

DELETE

7

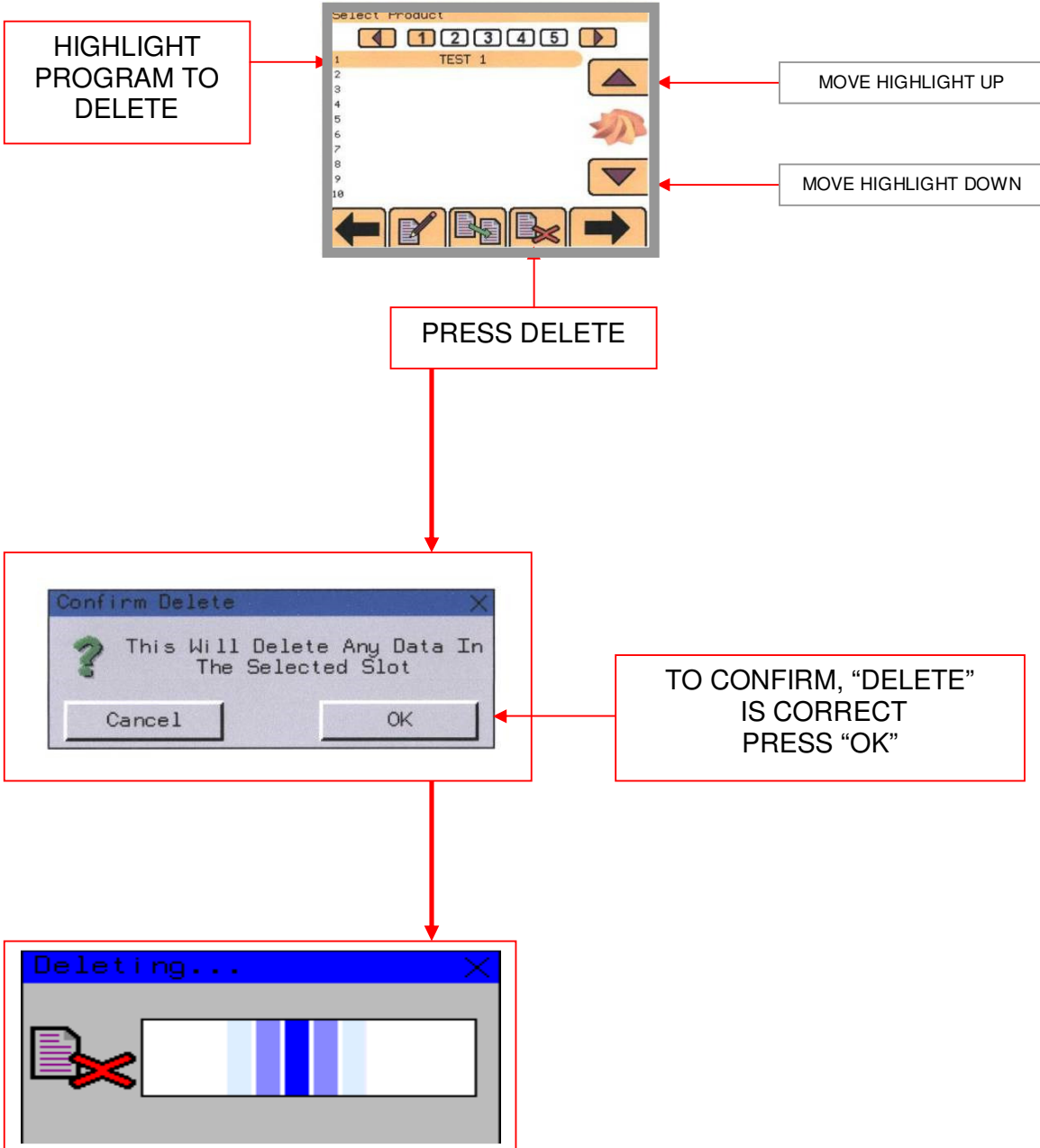

CAUTION

DO NOT ATTEMPT TO MAKE ADJUSTMENTS UNLESS YOU ARE FULLY AWARE OF THE RESULTS

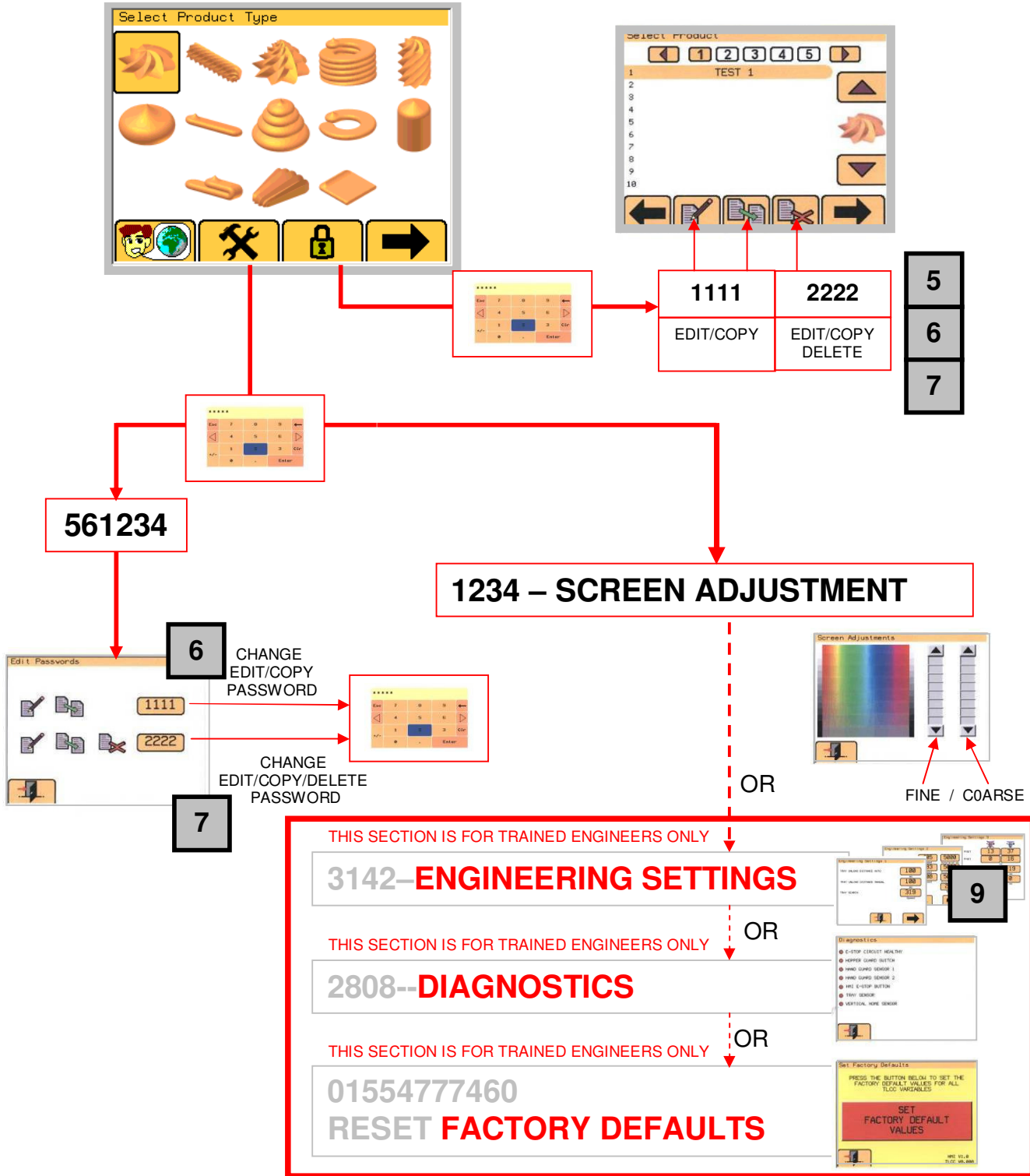

ENGINEERING SETTINGS (1)

9/1

THIS SECTION IS FOR TRAINED ENGINEERS ONLY

The screenshot shows the 'Engineering Settings 1' screen with the following elements:

- TRAY UNLOAD DISTANCE MANUAL:** A numeric field displaying '100' with 'MM' above it. A callout box explains: 'IN MANUAL MODE: DISTANCE THE LEADING EDGE OF THE TRAY IS BROUGHT BACK PASSED THE TRAY SENSOR, WHEN RETURNING TO OPERATOR'. A small keypad icon is shown above this field.
- TRAY SEARCH:** A numeric field displaying '319' with 'MM' above it and 'Speed' below it. A callout box explains: 'SPEED VALUE THAT TRAY IS FED UP TO TRAY SENSOR'. A small keypad icon is shown above this field.
- Navigation Buttons:** At the bottom, there are two buttons: one with a left-pointing arrow and a tray icon (labeled 'EXIT THIS SCREEN'), and one with a right-pointing arrow (labeled 'GO TO NEXT SCREEN ENGINEERING SETTING 2 (NEXT PAGE)').

CAUTION

DO NOT ATTEMPT TO MAKE ADJUSTMENTS UNLESS YOU ARE FULLY AWARE OF THE RESULTS

ENGINEERING SETTINGS (2)

9/2

THIS SECTION IS FOR TRAINED ENGINEERS ONLY

DEFAULT TRAY SPEED
(MOVEMENT BETWEEN ROWS)



DEFAULT JOG SPEED
(VERTICAL AFTER DEPOSIT)

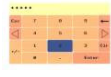

DEFAULT SPEED OF PUMP
(100% VALUE IN PRODUCT SETUP PROGRAM)

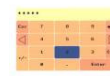

Engineering Settings 2

DEFAULT PUMP	700 Speed	3000 Acceleration
DEFAULT JOG	250 Speed	5000 Acceleration
DEFAULT TRAY	600 Speed	5000 Acceleration
PRIME PUMP		250 Speed

← →

DEFAULT ACCELERATION FOR PUMP



DEFAULT ACCELERATION FOR JOG



DEFAULT ACCELERATION FOR TRAY



PUMP SPEED WHEN USING PRIME BUTTON



EXIT THIS SCREEN

GO TO PREVIOUS SCREEN
ENGINEERING SETTING 1
(PREVIOUS PAGE)

GO TO NEXT SCREEN
ENGINEERING SETTING 3
(NEXT PAGE)

CAUTION

DO NOT ATTEMPT TO MAKE ADJUSTMENTS UNLESS YOU ARE FULLY AWARE OF THE RESULTS

ENGINEERING SETTINGS (3)

9/3

THIS SECTION IS FOR TRAINED ENGINEERS ONLY

OFFSET HEIGHT VALUE (mm)
**HARD DOUGH HOPPER
NON-ROTARY TEMPLATE**

OFFSET HEIGHT VALUE IS
FACTORY SET AND SHOULD NOT
BE CHANGED UNLESS
INSTRUCTED TO DO SO.
**DAMAGE TO THE MACHINE
COULD OCCUR**

OFFSET HEIGHT VALUE (mm)
**HARD DOUGH HOPPER
ROTARY TEMPLATE**

OFFSET HEIGHT VALUE (mm)
**SOFT DOUGH HOPPER
ROTARY TEMPLATE**

OFFSET HEIGHT VALUE (mm)
**SOFT DOUGH HOPPER
NON-ROTARY TEMPLATE**

DISTANCE (mm) FROM **HARD**
DOUGH HOPPER DEPOSITING
CENTRELINE TO TRAY EDGE
DETECTION POINT
(USED IN ROW SPACING CALCULATIONS)

DISTANCE (mm) FROM **SOFT**
DOUGH HOPPER DEPOSITING
CENTRELINE TO TRAY EDGE
DETECTION POINT
(USED IN ROW SPACING CALCULATIONS)

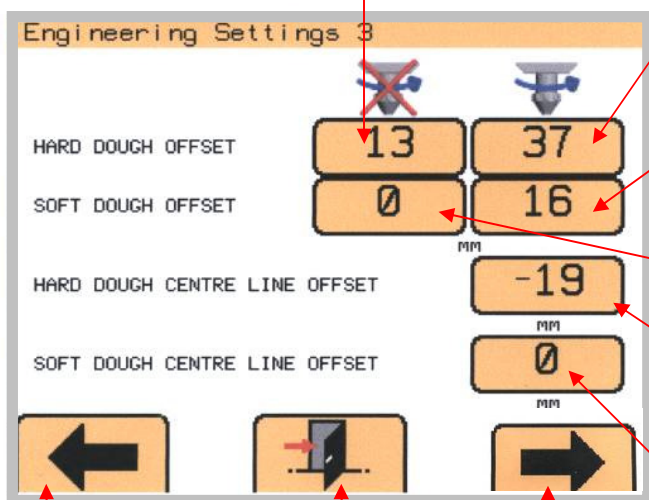

EXIT
THIS SCREEN

GO TO PREVIOUS SCREEN
ENGINEERING SETTING 2
(PREVIOUS PAGE)

GO TO NEXT SCREEN
ENGINEERING SETTING 4
(NEXT PAGE)

CAUTION

**DO NOT ATTEMPT TO MAKE ADJUSTMENTS UNLESS YOU ARE
FULLY AWARE OF THE RESULTS**

THIS SECTION IS FOR TRAINED ENGINEERS ONLY

GEARBOX RATIOS

The screenshot shows the 'Engineering Settings 4' screen with the following settings:

Setting	Value 1	Value 2
PUMP GEARBOX RATIO	10	1
TRAY GEARBOX RATIO	10	1
JOG GEARBOX RATIO	15	1
ROTARY GEARBOX RATIO	10	1

Navigation and Exit options:

- Left arrow: GO TO PREVIOUS SCREEN ENGINEERING SETTING 3 (PREVIOUS PAGE)
- Center icon: EXIT THIS SCREEN
- Right arrow: GO TO NEXT SCREEN ENGINEERING SETTING 5 (NEXT PAGE)

Labels on the right side of the screen:

- PUMP
- TRAY
- JOG
- ROTARY

CAUTION

DO NOT ATTEMPT TO MAKE ADJUSTMENTS UNLESS YOU ARE FULLY AWARE OF THE RESULTS

THIS SECTION IS FOR TRAINED ENGINEERS ONLY

WIPE BACK DEFAULT SETTINGS (SEE 5A)

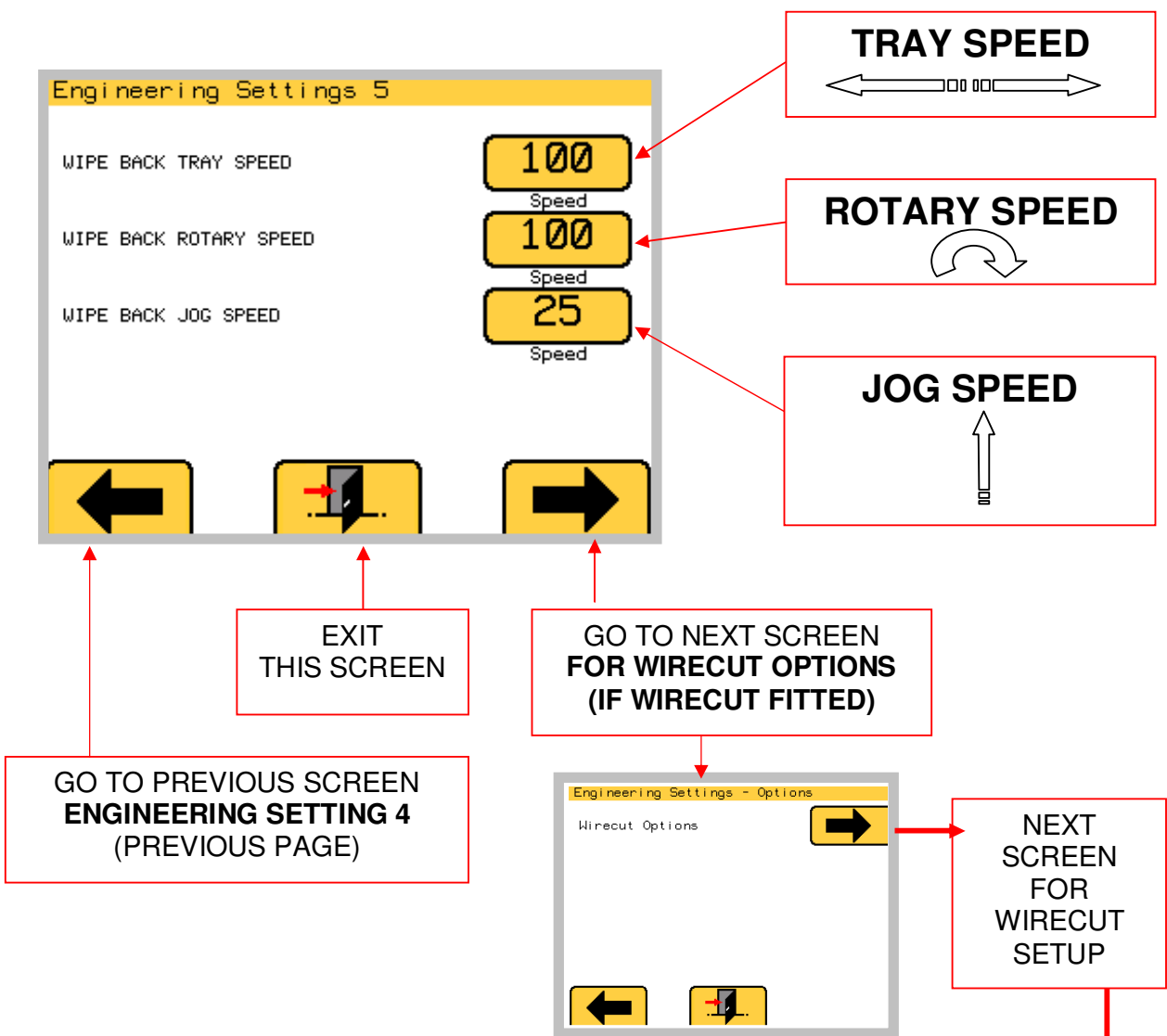

CAUTION

DO NOT ATTEMPT TO MAKE ADJUSTMENTS UNLESS YOU ARE FULLY AWARE OF THE RESULTS

NEXT PAGE

WIRECUT SETTINGS

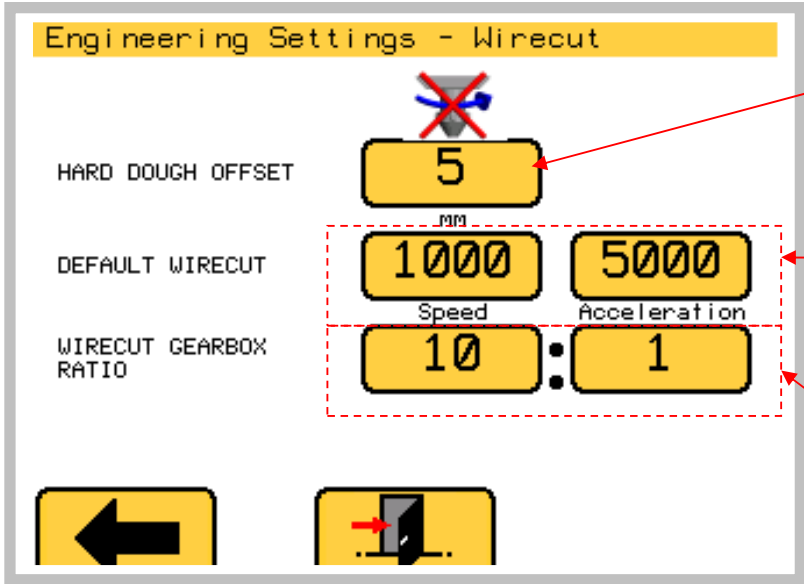

**HARD DOUGH
OFFSET**

**WIRECUT
SPEED +
ACCELERATION**

**WIRECUT
GEARBOX RATIO**

**EXIT
THIS SCREEN**

**GO TO PREVIOUS SCREEN
ENGINEERING SETTING 4
(PREVIOUS PAGE)**

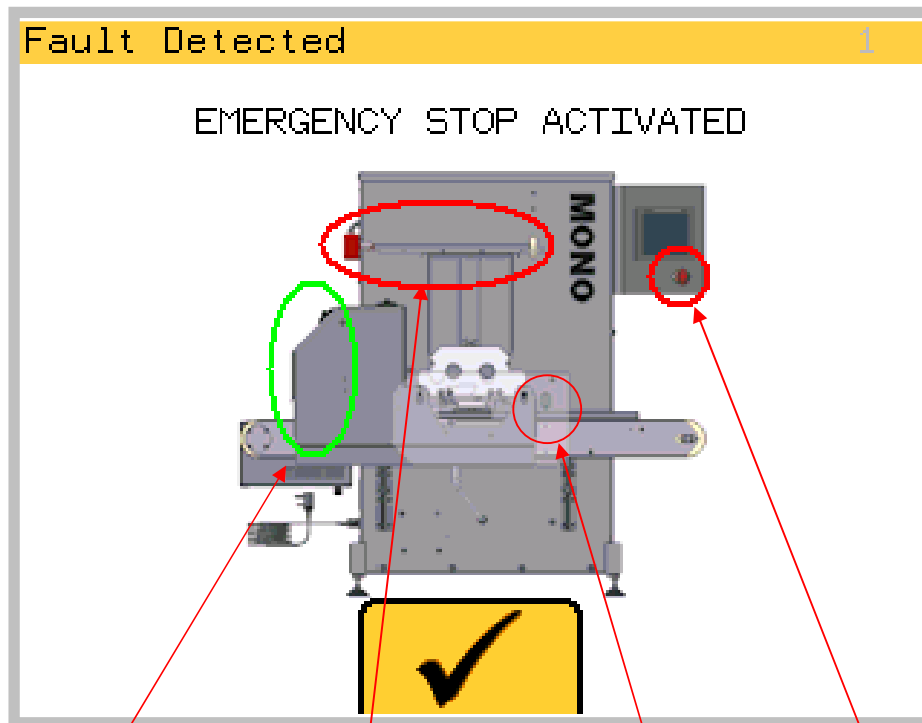

WIRECUT COVER
(IF FITTED)

HOPPER COVER

SAFETY BEAM

STOP BUTTON

THIS SCREEN INDICATES A FAULT CONDITION IN THE SAFETY AREAS.

WHEN **RED**, CLOSE COVER OR CLEAR OBSTRUCTIONS TO CLEAR FAULT.
WHEN INDICATOR GOES **GREEN**, FAULT HAS BEEN CORRECTED AT THAT POSITION.

PRESS  BUTTON TO CLEAR SCREEN

CAUTION

DO NOT ATTEMPT TO MAKE ADJUSTMENTS UNLESS YOU ARE FULLY AWARE OF THE RESULTS

IF THE FOLLOWING SCREEN APPEARS, CHECK THAT THE TABLE MOVEMENT ETC. IS NOT JAMMED WITH SOMETHING. IF IT IS, CLEAR THE OBSTRUCTION AND PRESS  TO PROCEED.

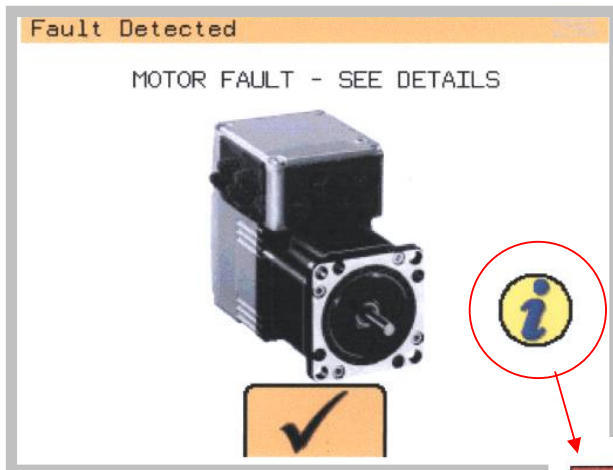

PRESS THIS BUTTON IF MORE INFORMATION IS REQUIRED AS TO WHICH MOTOR IS AT FAULT

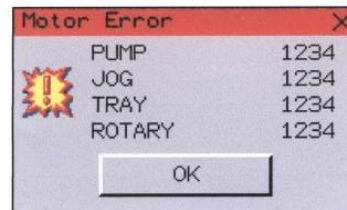

IF THE FAULT IS NOT OBVIOUS AND NOT ABLE TO BE CLEARED SAFELY, A SUITABLY TRAINED ENGINEER SHOULD BE CALLED

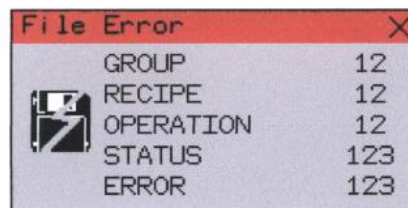

ERROR WHEN LOADING/SAVING RECIPE DATA TO HMI STORAGE CARD
PLEASE CONTACT SERVICE DEPT. / ENGINEER IF PROBLEM PERSISTS

11.0 MAINTENANCE

Under most conditions the machine only needs to be kept clean and used as instructed in this manual.

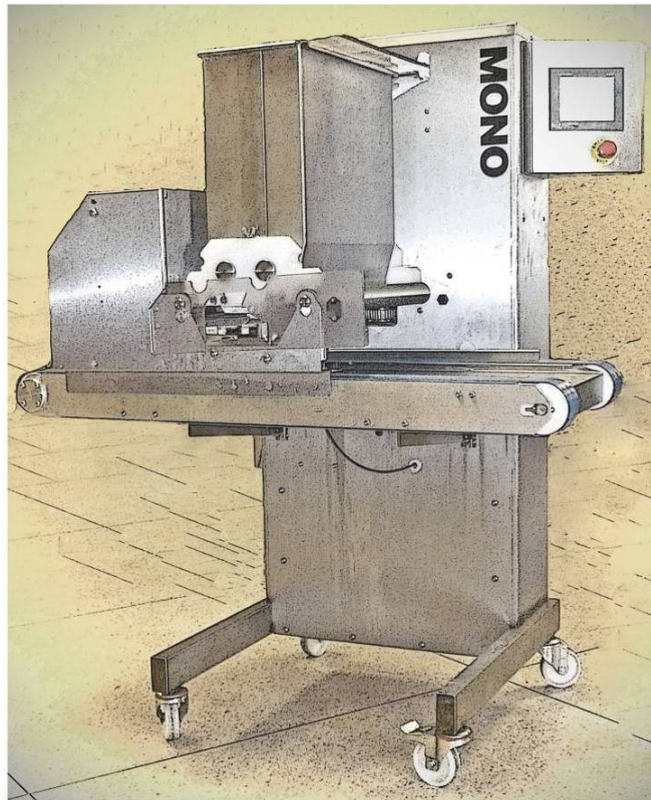

**WARNING: DO NOT UNDER ANY CIRCUMSTANCES
USE A WATER HOSE OR PRESSURE WASHER TO
CLEAN THIS MACHINE.**

Mono Omega Touch

Check and Maintenance Schedule

Operation	Daily	weekly	3 monthly	Yearly
Clean depositor as per instructions in manual	*			
Check condition of supply lead and plug	*			
check fit of guards	*			
Clean under conveyor belts		*		
Check hopper seals		*		
Check end cap seals		*		
Check condition and tension of conveyor, adjust / replace as required			*	
Check end cap bearings			*	
check alignment of sensors on guards			*	
Check tray sensor is secure			*	
Check condition of idle roller bearings				*
Check condition of drive shaft bearings				*
Check condition and tension of chain and grease as required				*
Grease slides as required				*
adjust eccentric guide rollers as required				*
adjust concentric guide rollers as required				*
Check and grease all slide plates as required				*
Check all motor mounts are tight				*
inspect electrical connections and tighten as required				*

Under no circumstances should maintenance or cleaning of this machine be done with the power connected

12.0 SPARES AND SERVICE

If a fault arises, please do not hesitate to contact the Customer Service Department, quoting the **machine serial number** on the silver information plate of the machine and on the front cover of this manual

UK SERVICE, SPARES and OVERSEAS SUPPORT:

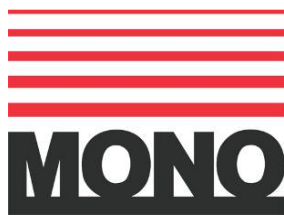

Queensway
Swansea West Industrial Estate
Swansea.
SA5 4EB
UK

email:spares@monoequip.com
Spares Tel. +44(0)1792 564039
Web site:www.monoequip.com

Main Tel. 01792 561234
Fax. 01792 561016

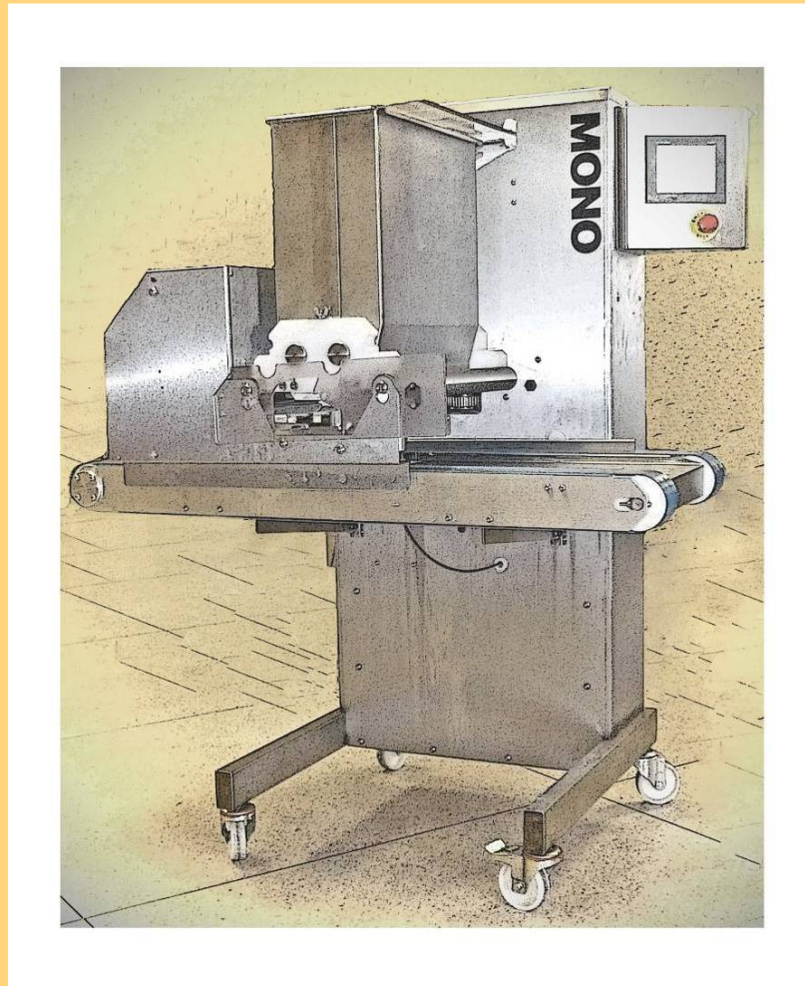

13.0 SPARES

**OMEGA PLUS
(INCLUDING WIRECUT VERSION)**

ELECTRICAL COMPONENT LAYOUT PARTS

OMEGA PLUS WIRECUT VERSION

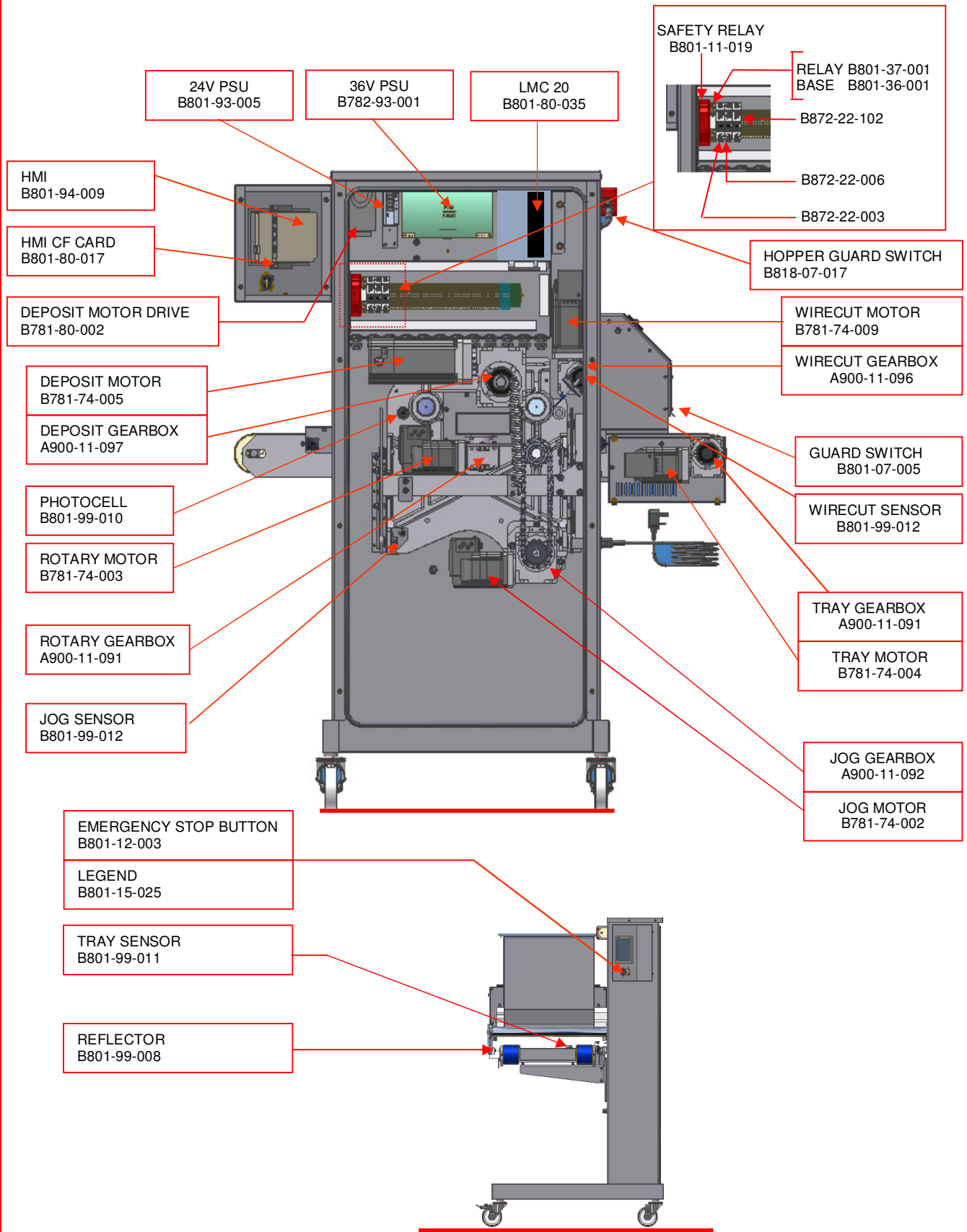

MECHANICAL COMPONENT LAYOUT PARTS

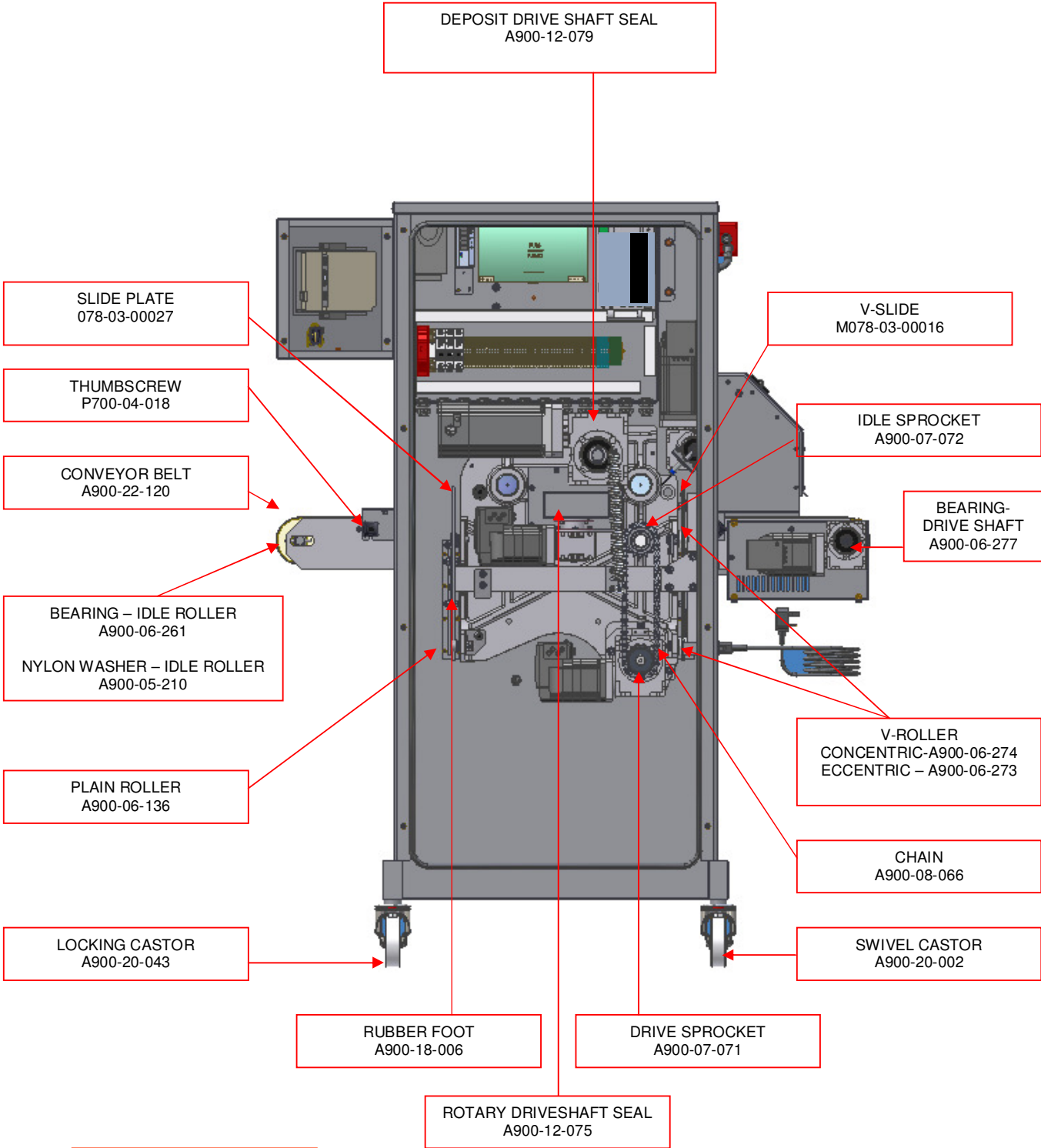

**REAR VIEW WITH
COVER REMOVED**

MECHANICAL COMPONENT LAYOUT PARTS

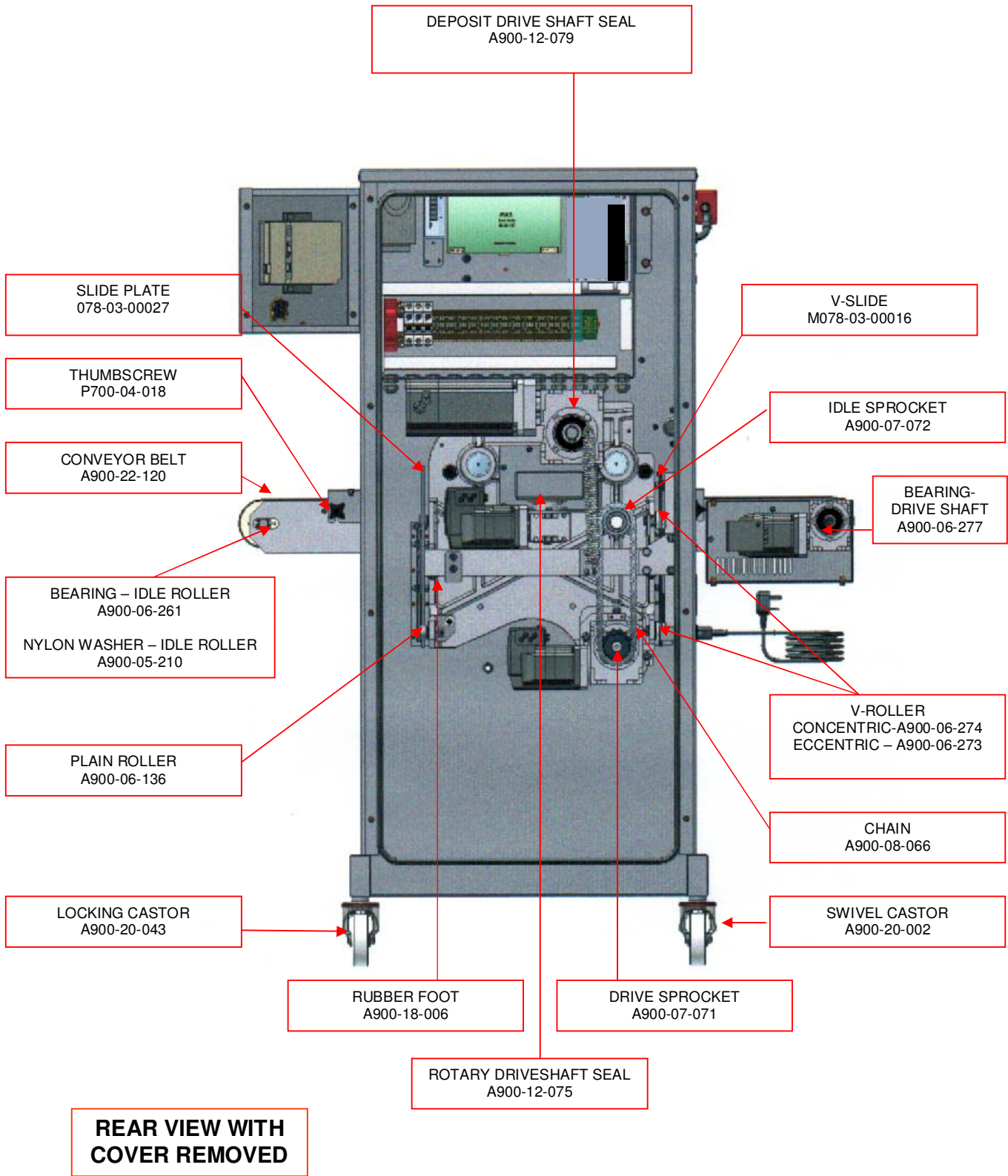

ELECTRICAL COMPONENT LAYOUT PARTS

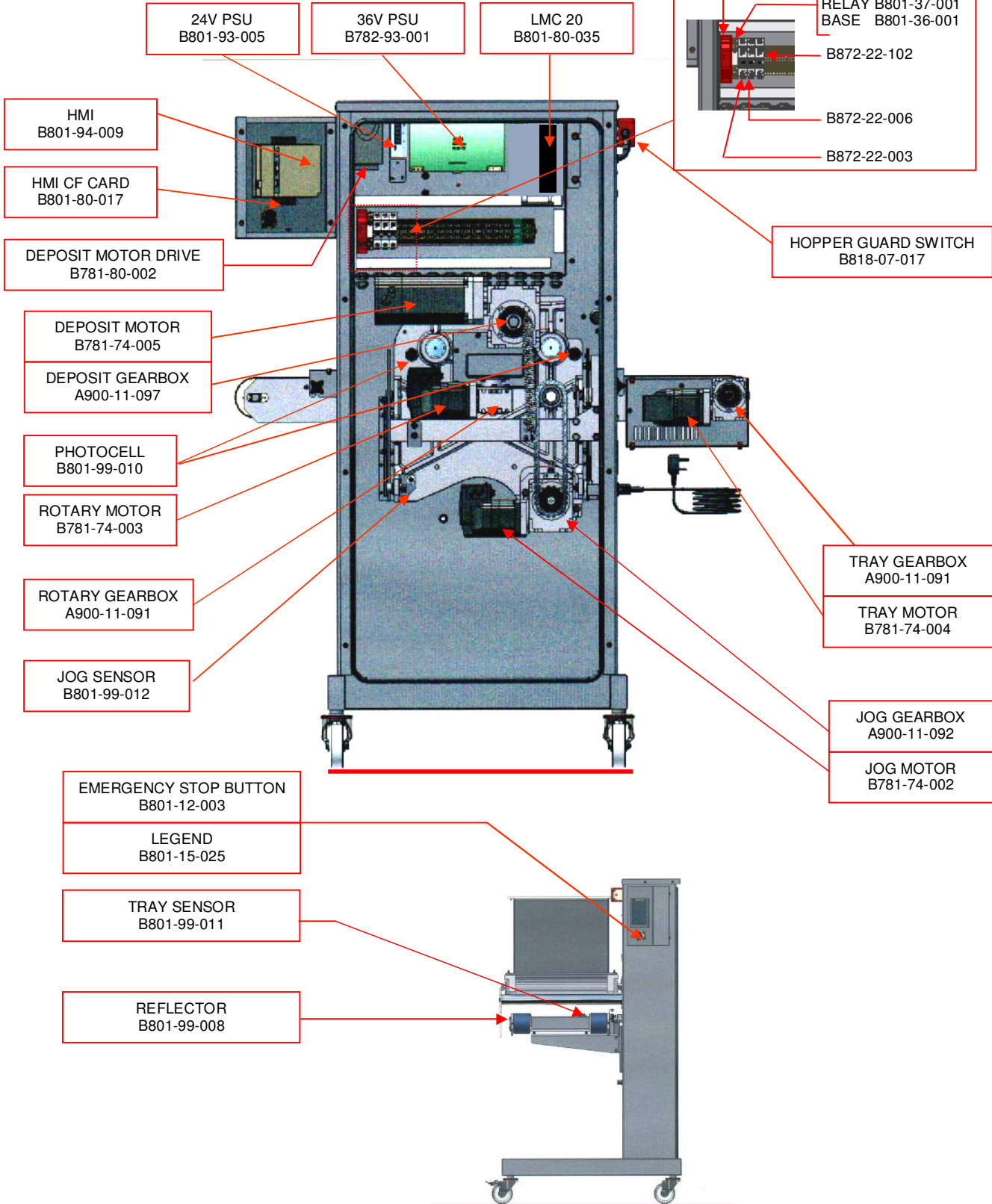

BASE MACHINE SPARES LIST (with wirecut)

Spares Item Description	Mono Part No.	Qty Req. per M/C
Deposit Gearbox	A900-11-097	1
Jog Gearbox	A900-11-092	1
Rotary Gearbox	A900-11-091	1
Tray Gearbox	A900-11-091	1
Concentric Guide Roller	A900-06-274	2
Eccentric Guide Roller	A900-06-273	2
V Slide	078-03-00016	1
Slide Plate	078-03-00027	1
Jog Drive Chain	A900-08-066	1
Simplex Sprocket 16T 1/2" Pitch	A900-07-071	1
Idler Sprocket 16T 1/2" Pitch	A900-07-072	1
Circlip-Ext Metric 14mm Dia	A900-01-280	1
Circlip-Ext Metric 24mm Dia	A900-01-193	1
Drive Shaft – Hopper	078-03-00015	1
Rotary Drive Shaft	078-03-00011	1
Drive Gear - Rotary Template	078-03-00010	1
Lip Seal (Rotary Drive Shaft)	A900-12-075	1
Lip Seal (Deposit Drive Shaft)	A900-12-079	1
Top Guard 400mm/450mm Hopper	078-09-00005	1
Top Guard 580mm Hopper	078-09-00044	1
End Guard	078-11-00020	1
Retainer – End Guard	078-11-00002	2
Seal-Rear Cover	A900-25-309	1

HARD DOUGH HOPPER PARTS

Omega PLUS

HOPPER FABRICATION

STANDARD CAPACITY

M078-09-00086 (400mm)
 M078-09-00042 (450mm)
 M078-09-00089 (580mm)

EXTENDED CAPACITY

M078-09-00087 (400mm)
 M078-09-00088 (450mm)
 M073-09-00092 (580mm)

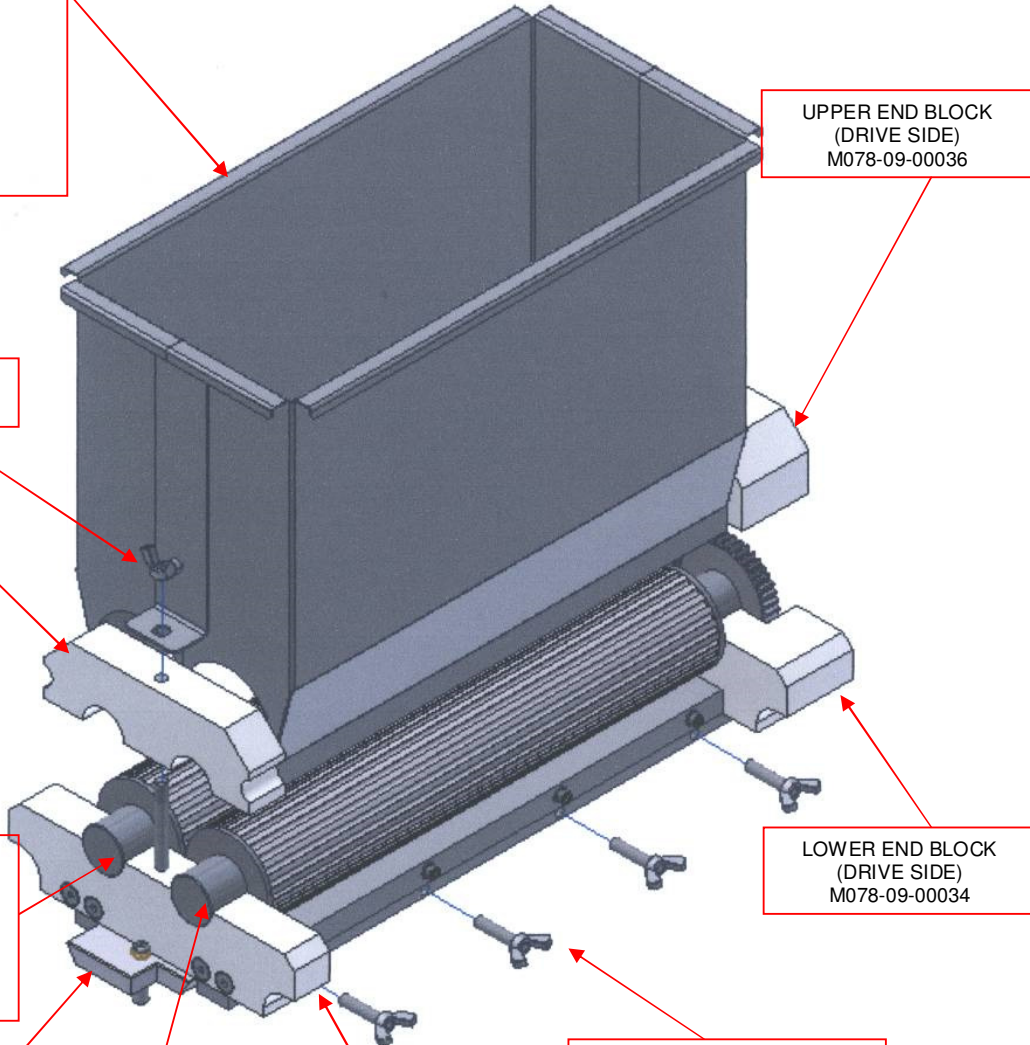

WINGNUT
 A900-04-147

UPPER END BLOCK
 (DRIVEN SIDE)
 M078-09-00037

DRIVE ROLLER

M078-09-00066 (400mm)
 M078-09-00060 (450mm)
 M078-09-00074 (580mm)

UPPER END BLOCK
 (DRIVE SIDE)
 M078-09-00036

LOWER END BLOCK
 (DRIVE SIDE)
 M078-09-00034

THUMBSCREW
 M078-09-00043

TEMPLATES

ROTARY
 ■ SMALL BORE
 ■ LARGE BORE
 STANDARD
 ■ SMALL BORE
 ■ LARGE BORE
 DIE
 SHEETING

DRIVEN ROLLER

M078-09-00067 (400mm)
 M078-09-00061 (450mm)
 M078-09-00075 (580mm)

LOWER END BLOCK
 (DRIVEN SIDE)
 M078-09-00035

SOFT DOUGH HOPPER PARTS

Omega PLUS

HOPPER FABRICATION

STANDARD CAPACITY
 M078-09-00008 (400mm)
 M078-09-00001 (450mm)
 M078-09-00046 (580mm)

EXTENDED CAPACITY
 M073-09-00200 (400mm)
 M073-09-00202 (450mm)
 M073-09-00203 (580mm)

END CAP ASSEMBLY (NON-DRIVE SIDE)
 M073-KMX002
 (END CAP AND BUSHES FITTED)

END CAP (NON-DRIVE SIDE)
 M073-09-03200

END CAP BUSH
 M073-09-00600

WINGNUT
 A900-04-043

HOPPER SEAL

A900-12-083 (400mm)
 A900-12-084 (450mm)
 A900-12-085 (580mm)

DRIVEN GEAR

M073-09-00702 (400mm)
 M073-09-01602 (450mm)
 M073-09-01702 (580mm)

WINGNUT
 A900-04-147

END CAP (DRIVE SIDE)
 M073-09-00500

END CAP ASSEMBLY (DRIVE SIDE)
 M073-KMX001
 (END CAP AND BUSHES FITTED)

END CAP BUSH
 M073-09-00600

DRIVE GEAR

M073-09-00700 (400mm)
 M073-09-01600 (450mm)
 M073-09-01700 (580mm)

TEMPLATES

ROTARY
 STANDARD
 DIE
 STAGGERED
 SHEETING
 ■ NON-DRIP
 ■ MULTI SHEETING
 INJECTION

END CAP SEAL
 A900-12-074

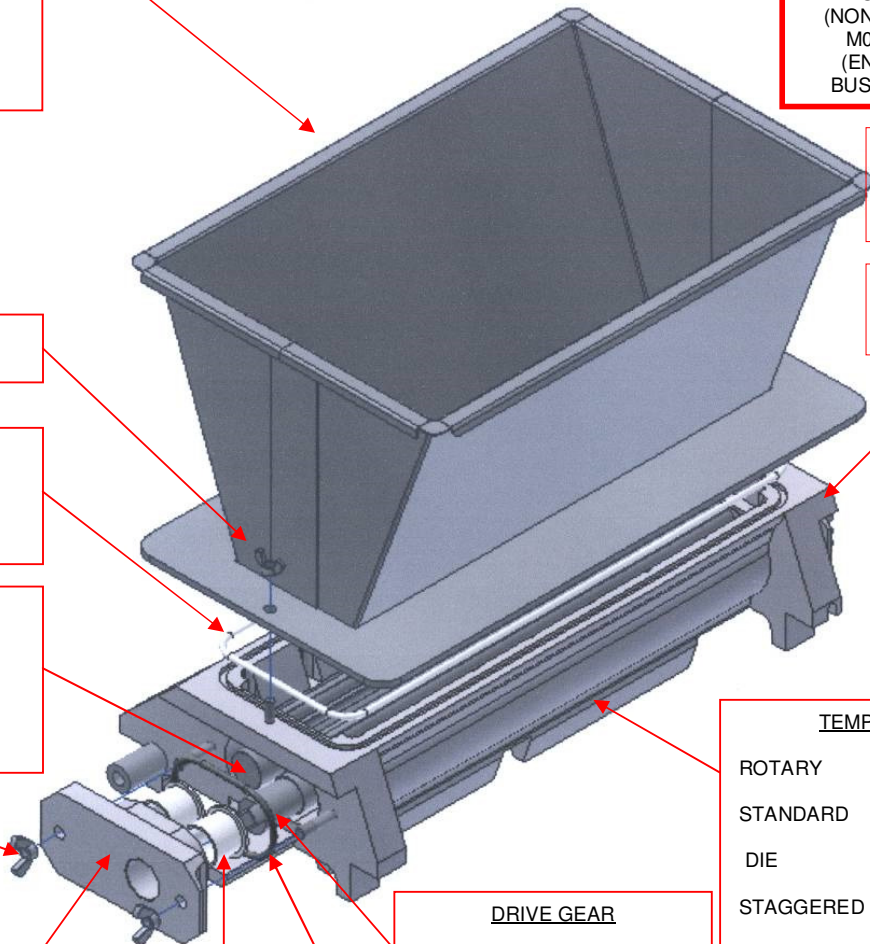

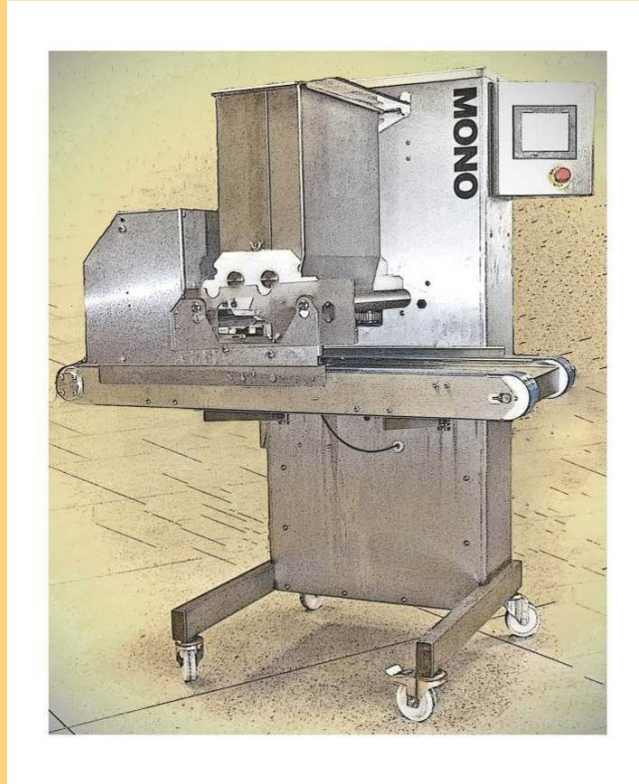

14.0 ELECTRICAL INFORMATION

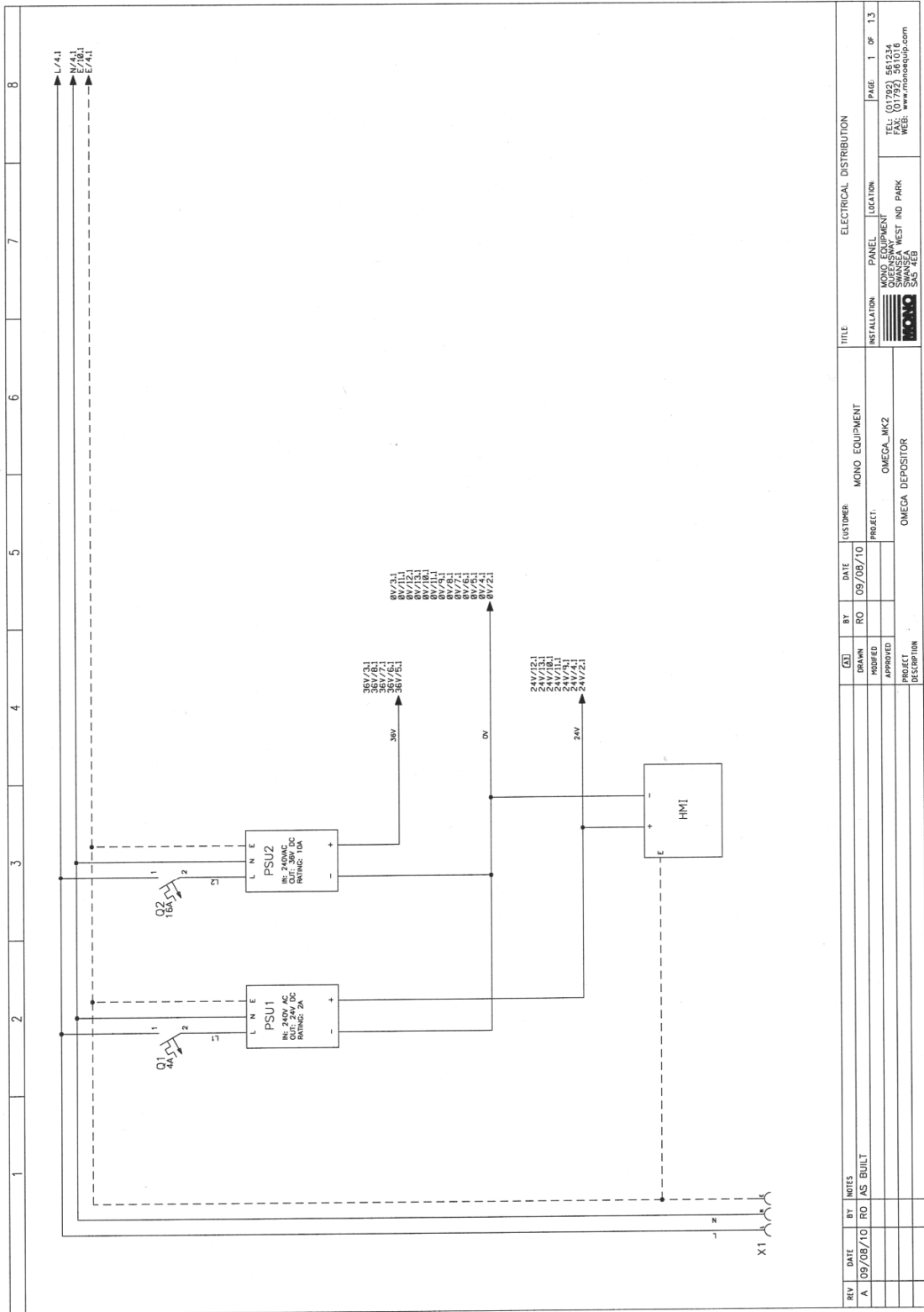

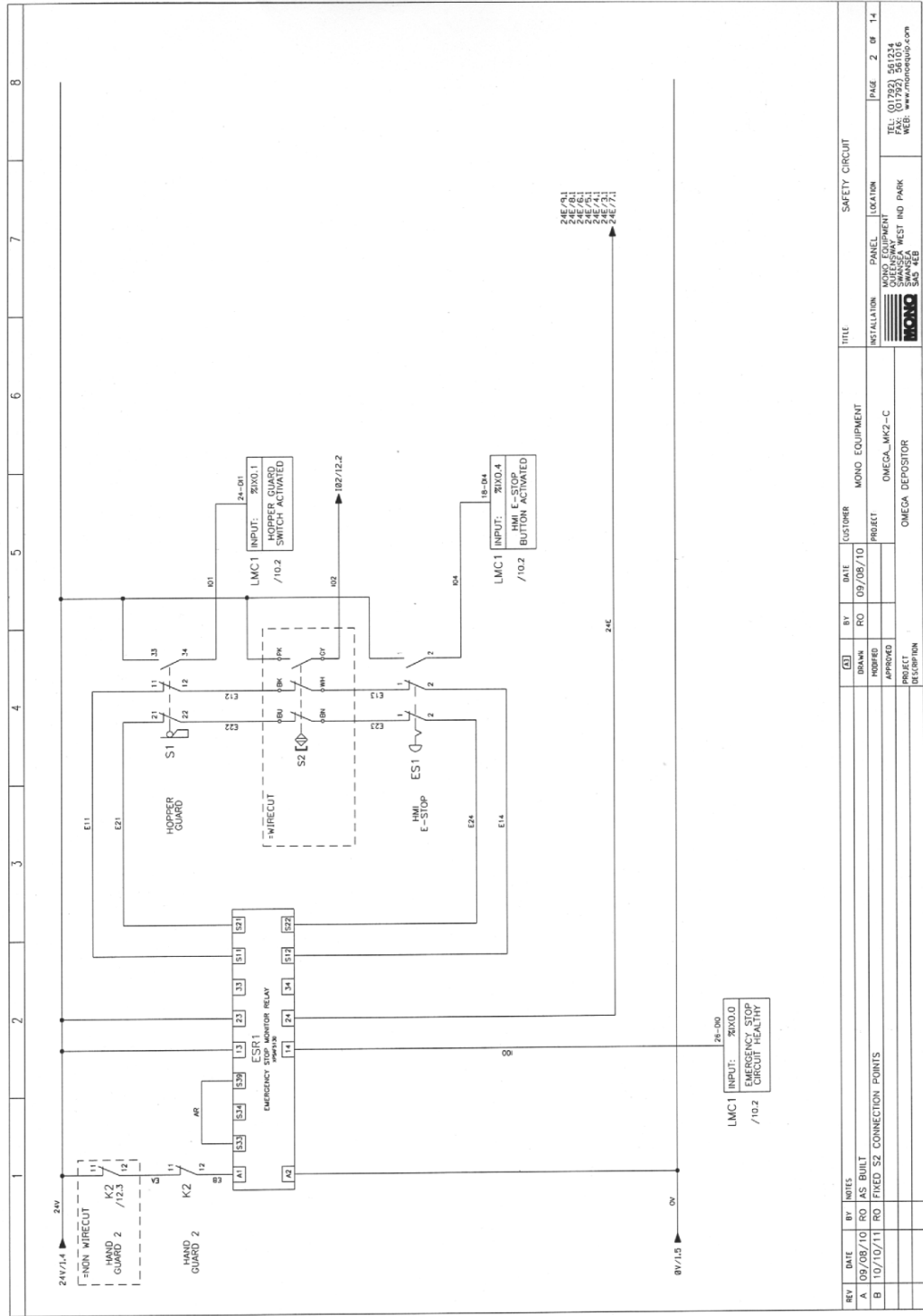

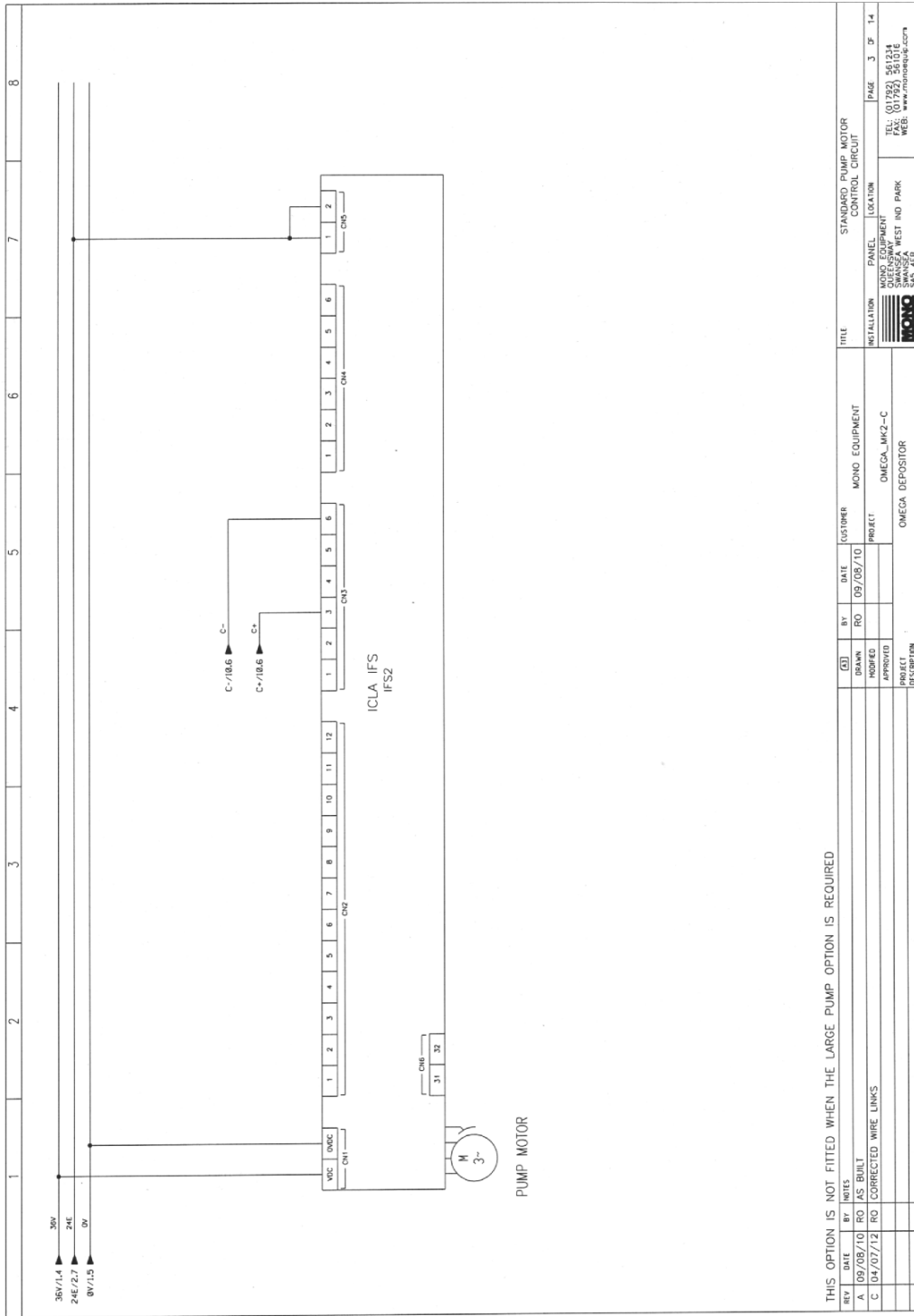

THIS OPTION IS NOT FITTED WHEN THE LARGE PUMP OPTION IS REQUIRED

REV	DATE	BY	NOTES
A	09/08/10	RO	AS BUILT
C	04/07/12	RO	CORRECTED WIRE LINKS

(S)	BY	DATE	CUSTOMER	MONO EQUIPMENT	TITLE
DRAWN	RO	09/08/10			STANDARD PUMP MOTOR CONTROL CIRCUIT
MODIFIED					
APPROVED					
PROJECT DESCRIPTION	OMEGA DEPOSITOR				
INSTALLATION	MONO INDUSTRIES				
PANEL LOCATION	MONO INDUSTRIES				
PROJECT	OMEGA MK2-C				
LOCATION	SWANSEA WEST IND PARK				
MONO	305 AEB				

PAGE	OF
3	14

TEL	TEL	WEB
(0)1782	561314	
		www.monobuild.com

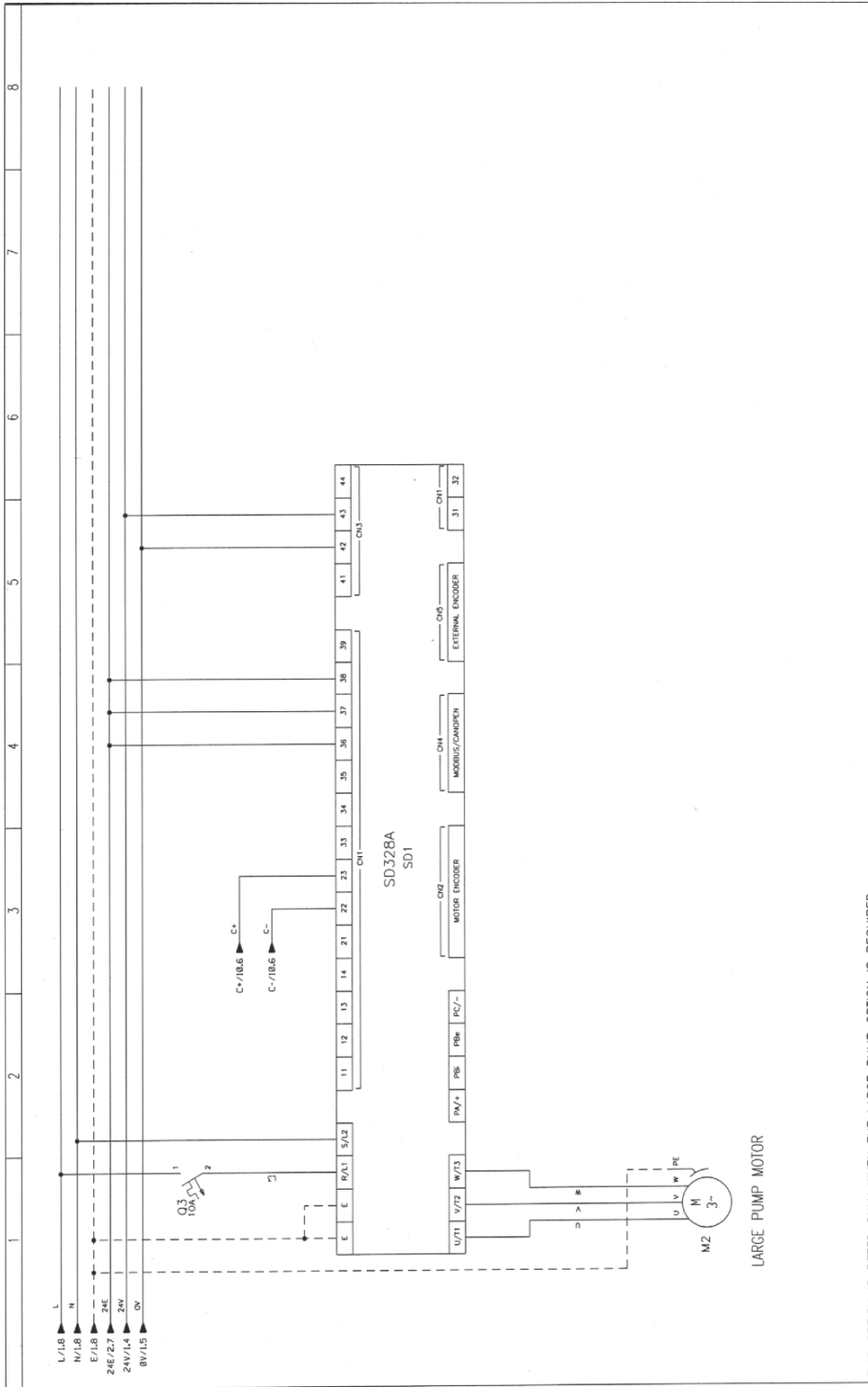

THIS OPTION IS FITTED ONLY WHEN THE LARGE PUMP OPTION IS REQUIRED

REV	DATE	BY	NOTES
A	09/08/10	RO	AS BUILT

(U)	DATE	CUSTOMER	MONO EQUIPMENT	TITLE	LARGE PUMP MOTOR OPTION
DRAWN	RO	09/09/10		INSTALLATION	CONTROL CIRCUIT
APPROVED			PROJECT	MONO	
PROJECT DESCRIPTION		OMEGA DEPOSITOR	OMEGA_MK2-C	PANEL LOCATION	
				MONO	
				USER'S MANUAL	
				SWANSEA	
				WEST ROY PARK	
				SOS 4EB	

PAGE 4 OF 14
 TEL: (01782) 561224
 FAX: (01782) 561224
 WEB: www.monobolp.com



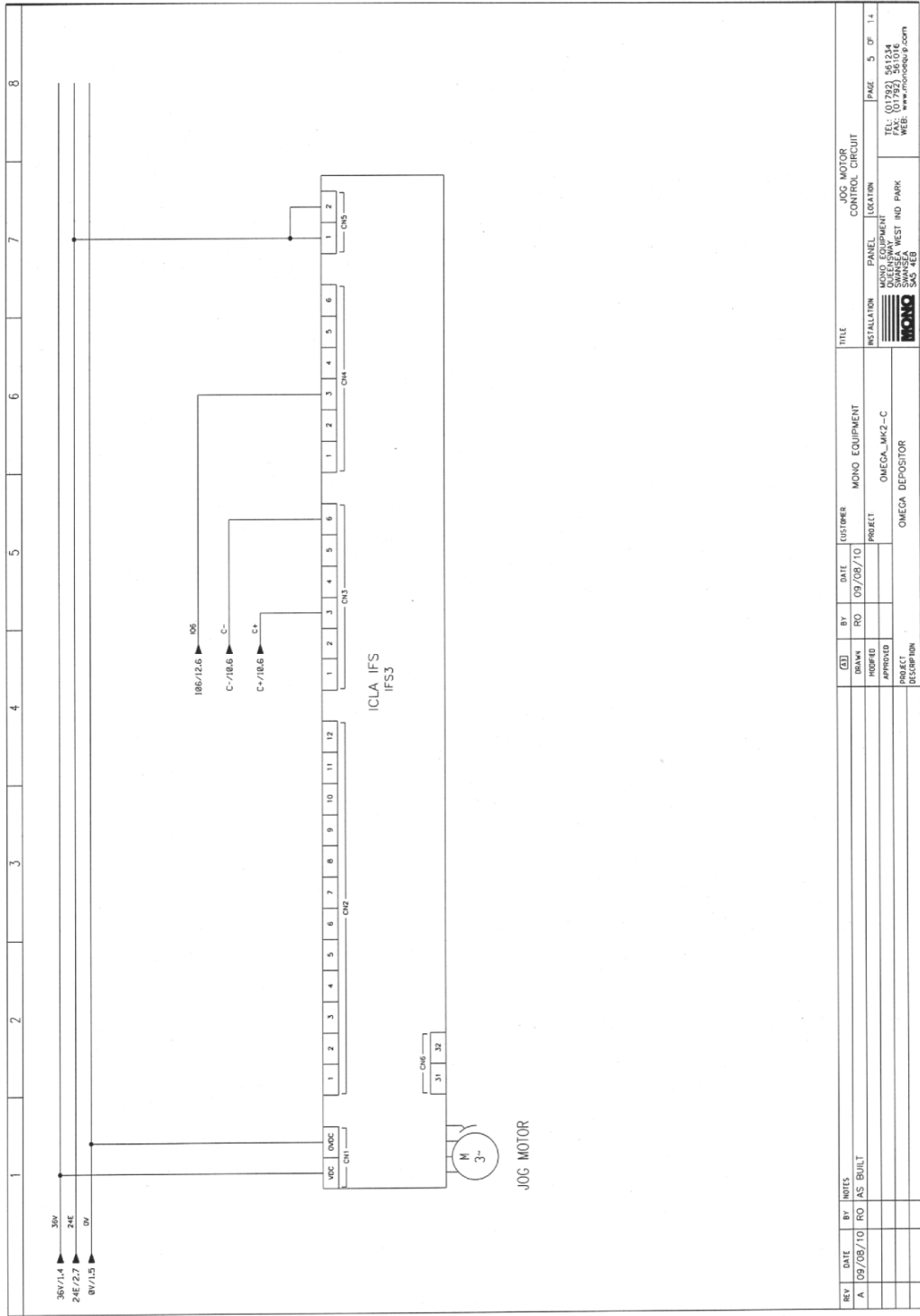

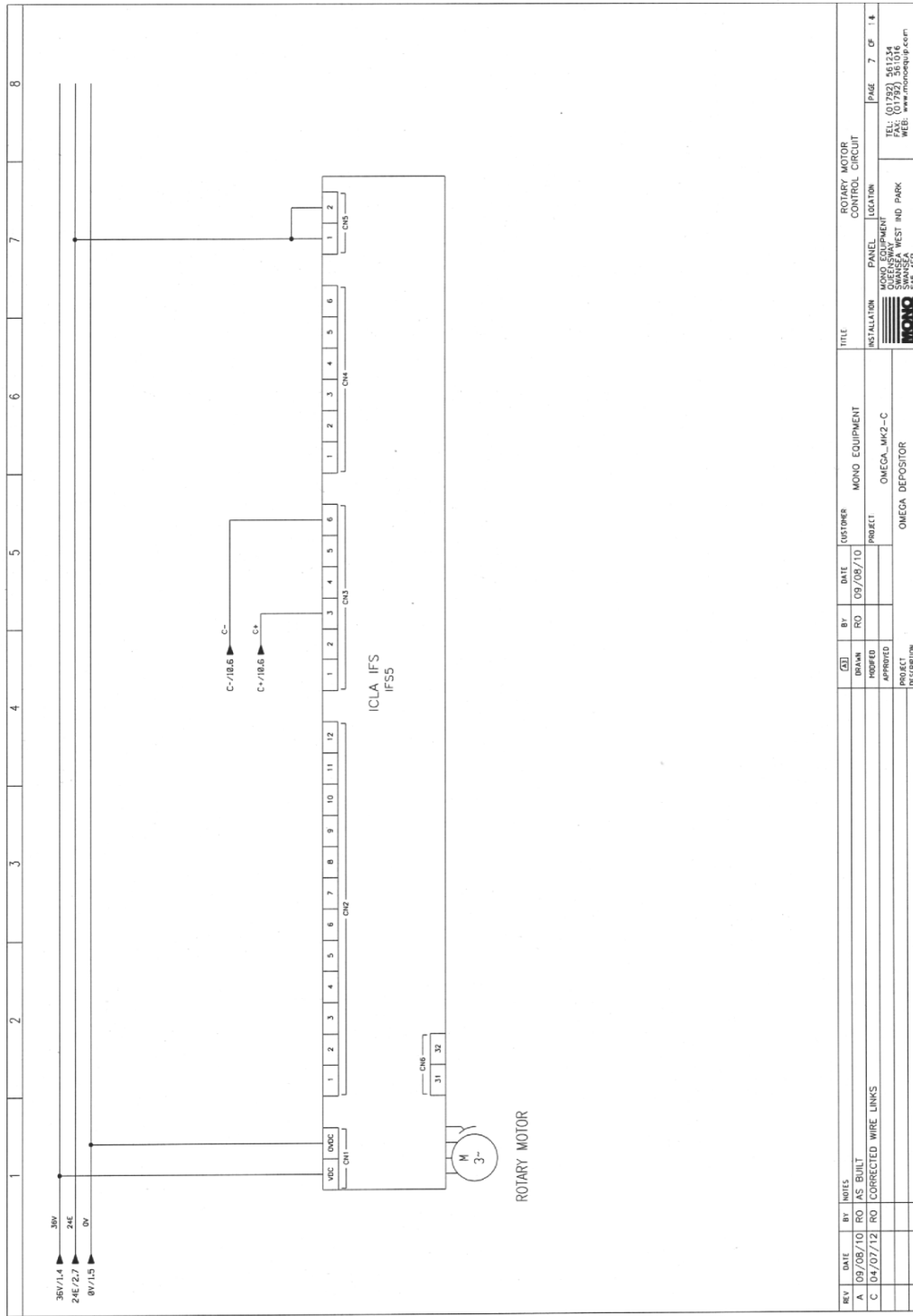

REV	DATE	BY	NOTES	QTY	BY	DATE	CUSTOMER	INSTALLATION	TITLE
A	09/08/10	RO	AS BUILT		RO	09/09/10	OMEGA DEPOSITOR	OMEGA_MW2-C	ROTARY MOTOR CONTROL CIRCUIT
C	04/07/12	RO	CORRECTED WIRE LINKS						

DESCRIPTION	PROJECT	OMEGA DEPOSITOR

INSTALLATION	PANEL	LOCATION
MONO	OMEGA DEPOSITOR	SHANESIA WEST MID PARK

DATE	TIME	BY
06/13/08		

TEL:	WEB:
(01792) 361338	www.monoequip.com



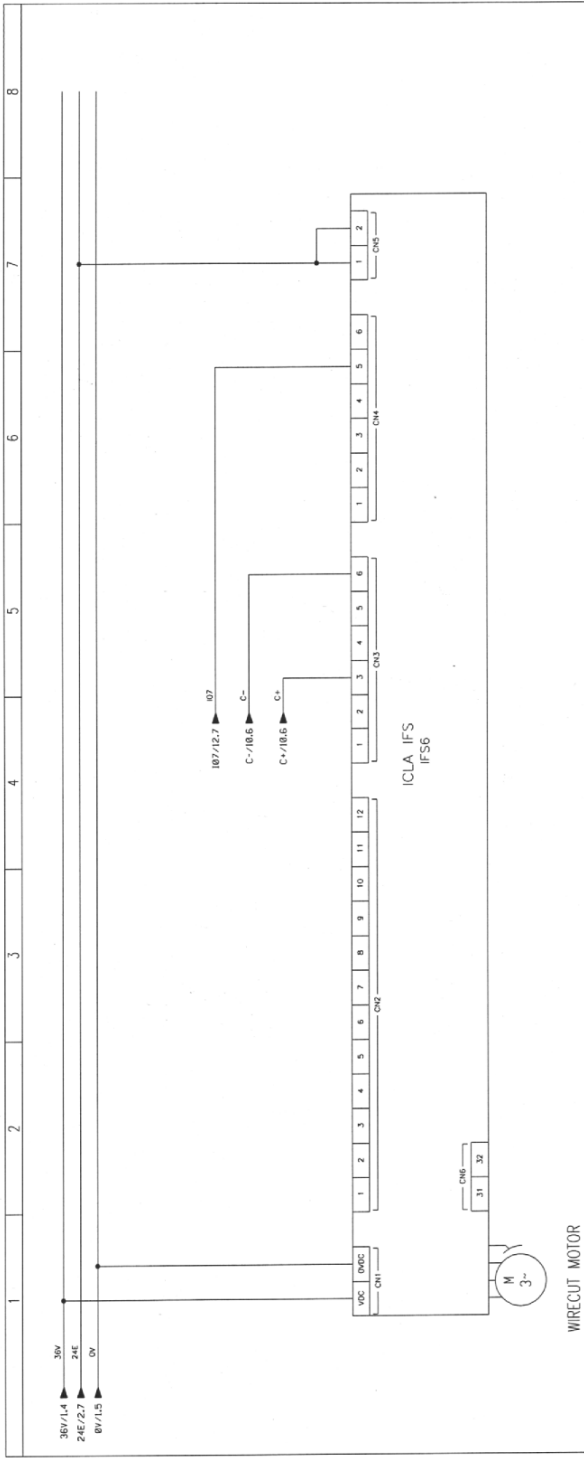

THIS OPTION IS FITTED ONLY WHEN THE WIRECUT OPTION IS REQUIRED

REV	DATE	BY	NOTES	DATE	CUSTOMER	MONG EQUIPMENT	TITLE
A	09/08/10	RO	AS BUILT	09/09/10		OMEGA MW2-C	WIRECUT MOTOR OPTION CONTROL CIRCUIT
C	04/07/12	RO	CORRECTED WIRE LINKS				

INSTALLATION	PANEL	LOCATION	PAGE
	OMEGA MW2-C	WEST IND PARK	B 9 14

PROJECT	DESCRIPTION
OMEGA DEPOSITOR	

TEL:	WEB:
(01792) 561518	www.monocorp.com



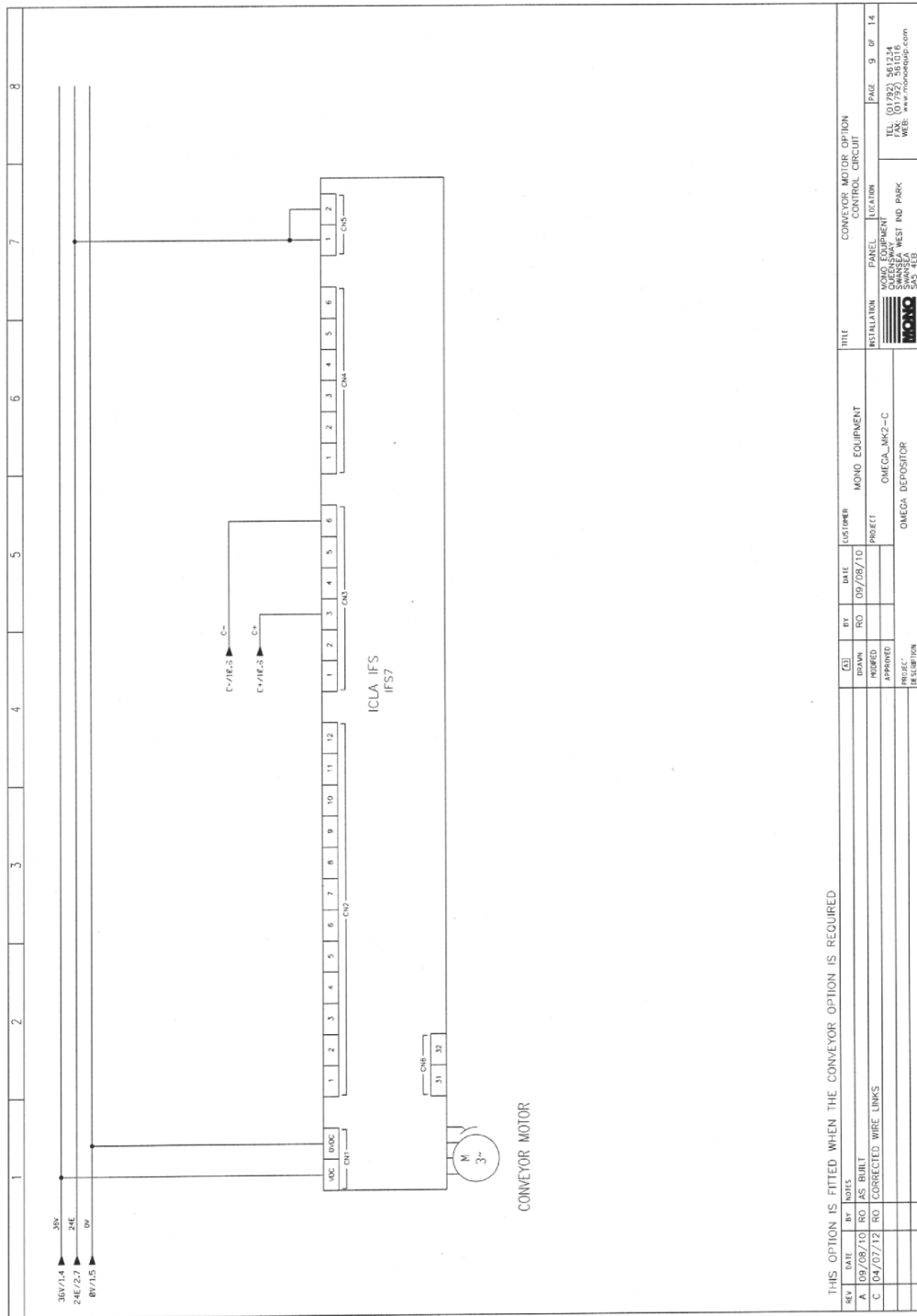

THIS OPTION IS FITTED WHEN THE CONVEYOR OPTION IS REQUIRED

REV	DATE	BY	DATE	DESCRIPTION	PROJECT	MOHO EQUIPMENT	TITLE	CONVEYOR MOTOR OPTION CONTROL CIRCUIT
A	09/08/10	RD	09/08/10	AS BUILT	OMEGA MK2-C	OMEGA DEPOSITOR	INSTALLATION PANEL LOCATION	MONO EQUIPMENT
C	04/07/12	RD		CORRECTED WIRE LINKS	OMEGA DEPOSITOR			MONO EQUIPMENT
								MONO EQUIPMENT
								MONO EQUIPMENT

MONO
 TEL: (01792) 561234
 FAX: (01792) 351016
 WEB: www.monosupplies.com



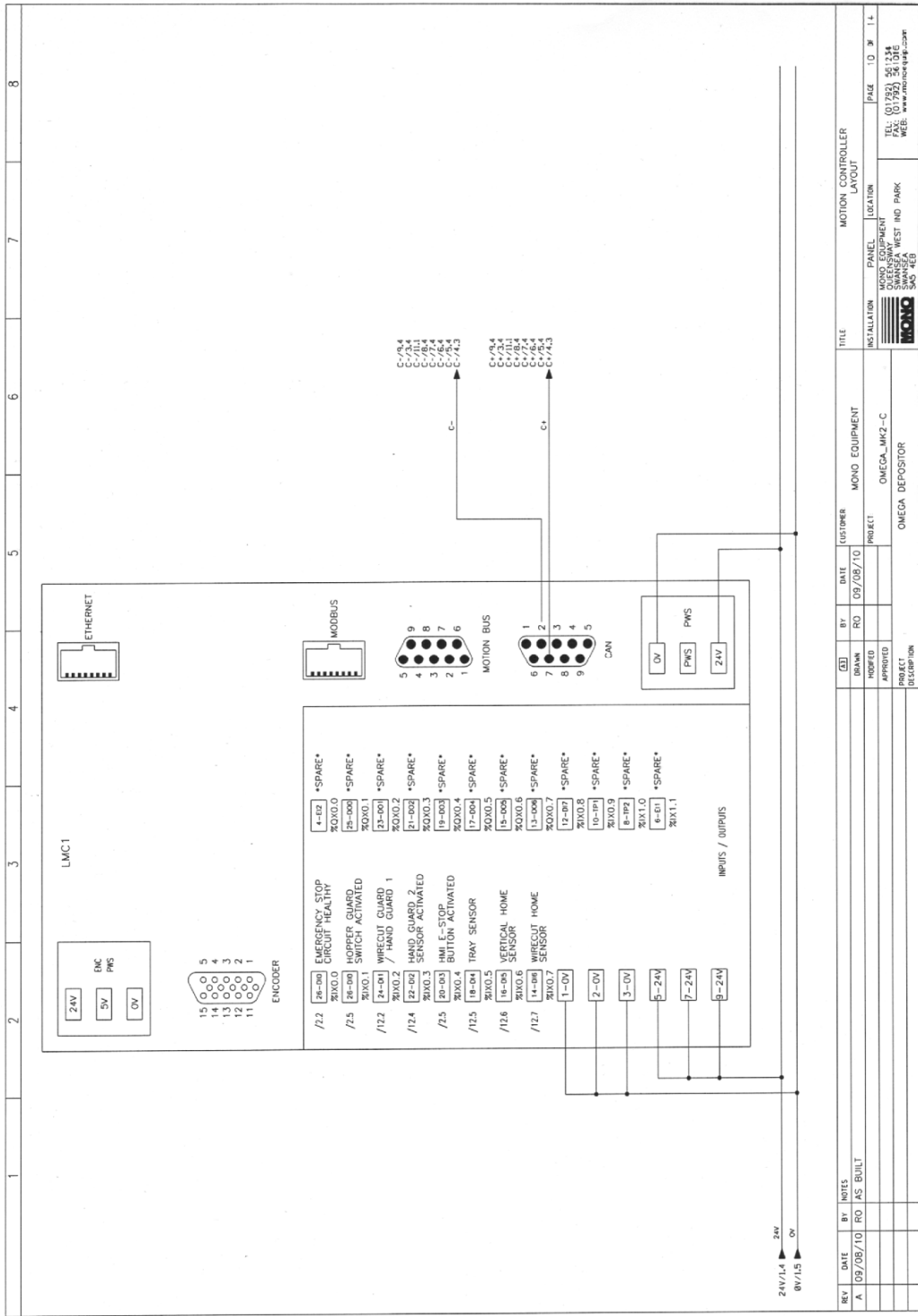

REV	DATE	BY	NOTES	DATE	BY	DATE	CUSTOMER	MONO EQUIPMENT	TITLE
A	08/08/10	RO	AS BUILT	09/08/10	RO	09/08/10	OMEGA DEPOSITOR	OMEGA_MW2-C	MOTION CONTROLLER LAYOUT
DRAWN: [] MODIFIED: [] APPROVED: [] PROJECT DESCRIPTION: []									
INSTALLATION: [] PANEL: [] LOCATION: [] MONO: []									
TEL: (01782) 951338 FAX: (01782) 951339 WEB: WWW.MONOINTECH.COM									



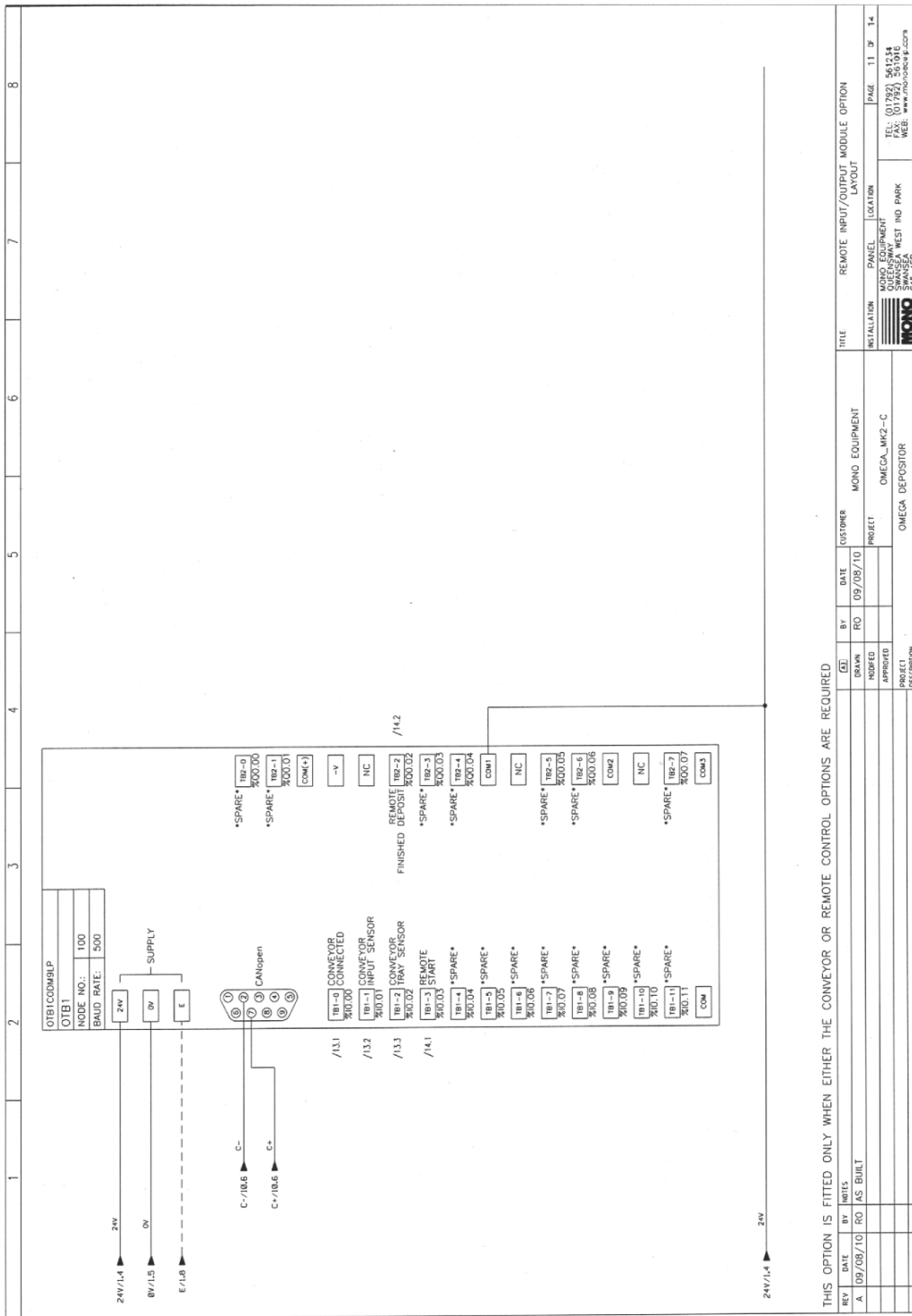

REV	DATE	BY	NOTES	DATE	BY	DATE	CUSTOMER	TITLE
A	09/08/10	RO	AS BUILT			09/09/10	OMEGA DEPOSITOR	OMEGA DEPOSITOR
				DRAWN	RO	PROJECT	OMEGA_MW2-C	MONO EQUIPMENT
				APPROVED				INSTALLATION
				PROJECT				USE OF EQUIPMENT
				DESCRIPTION				PANEL LOCATION
								SWANSEA WEST IND PARK
								SAS ZEB
								MONO
								TEL: (01782) 961234
								WEB: www.mono-pneuf.com
								Page 11 of 14

THIS OPTION IS FITTED ONLY WHEN EITHER THE CONVEYOR OR REMOTE CONTROL OPTIONS ARE REQUIRED

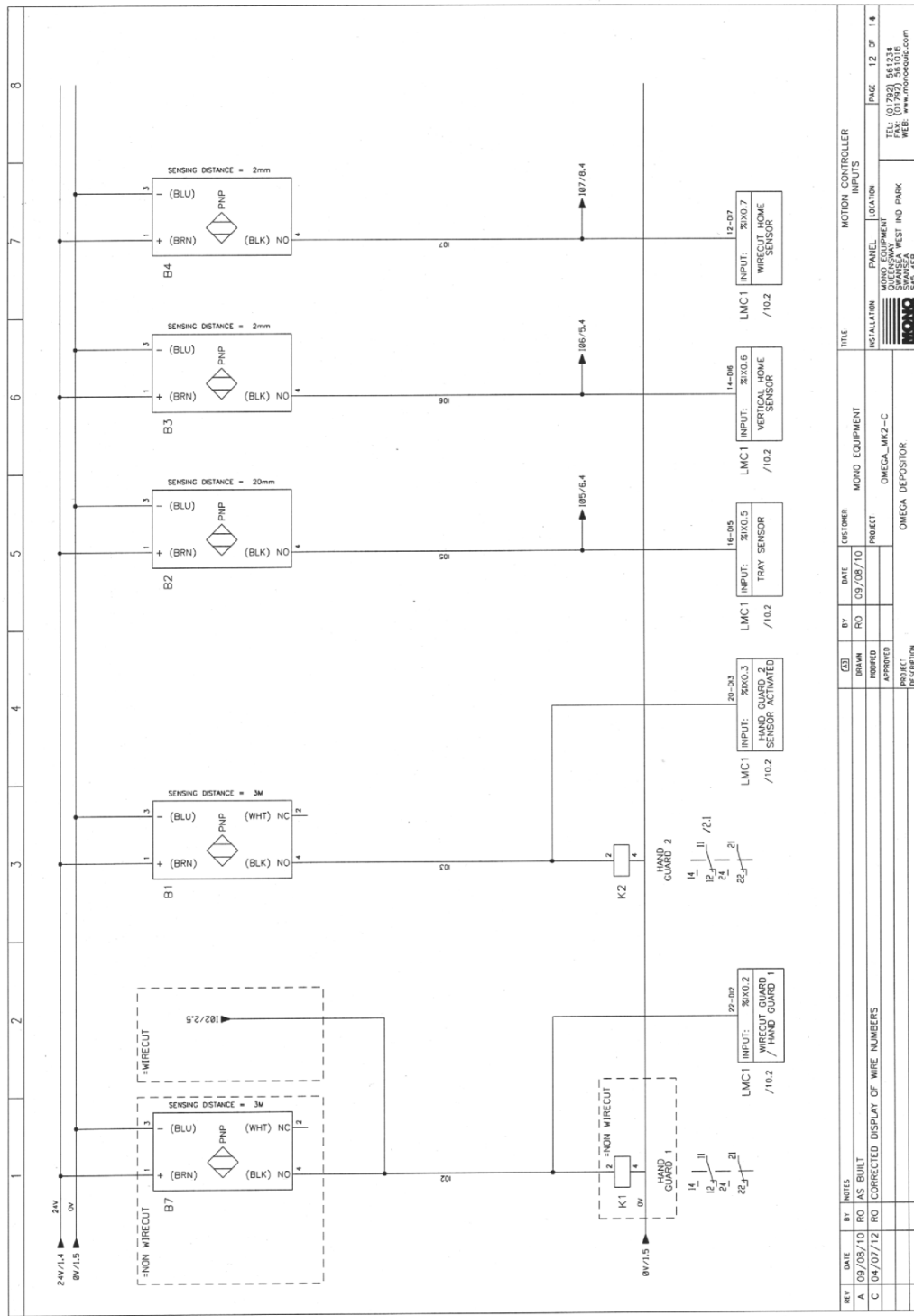

REV	DATE	BY	NOTES	TITLE	MOTION CONTROLLER INPUTS
A	09/08/10	RO	AS BUILT	INSTALLATION	PANEL LOCATION
C	04/07/12	RO	CORRECTED DISPLAY OF WIRE NUMBERS	MONO EQUIPMENT	MONO

DATE	BY	DATE	CUSTOMER	PROJECT	MONO DEPOSITOR
09/05/10	RO	09/05/10	OMEGA	OMEGA_MW2-C	OMEGA DEPOSITOR

WIRE NUMBER	DESCRIPTION
12-07	WIRECUT HOME SENSOR
14-06	VERTICAL HOME SENSOR
16-05	TRAY SENSOR
20-03	HAND GUARD 2 SENSOR ACTIVATED
22-02	WIRECUT GUARD / HAND GUARD 1



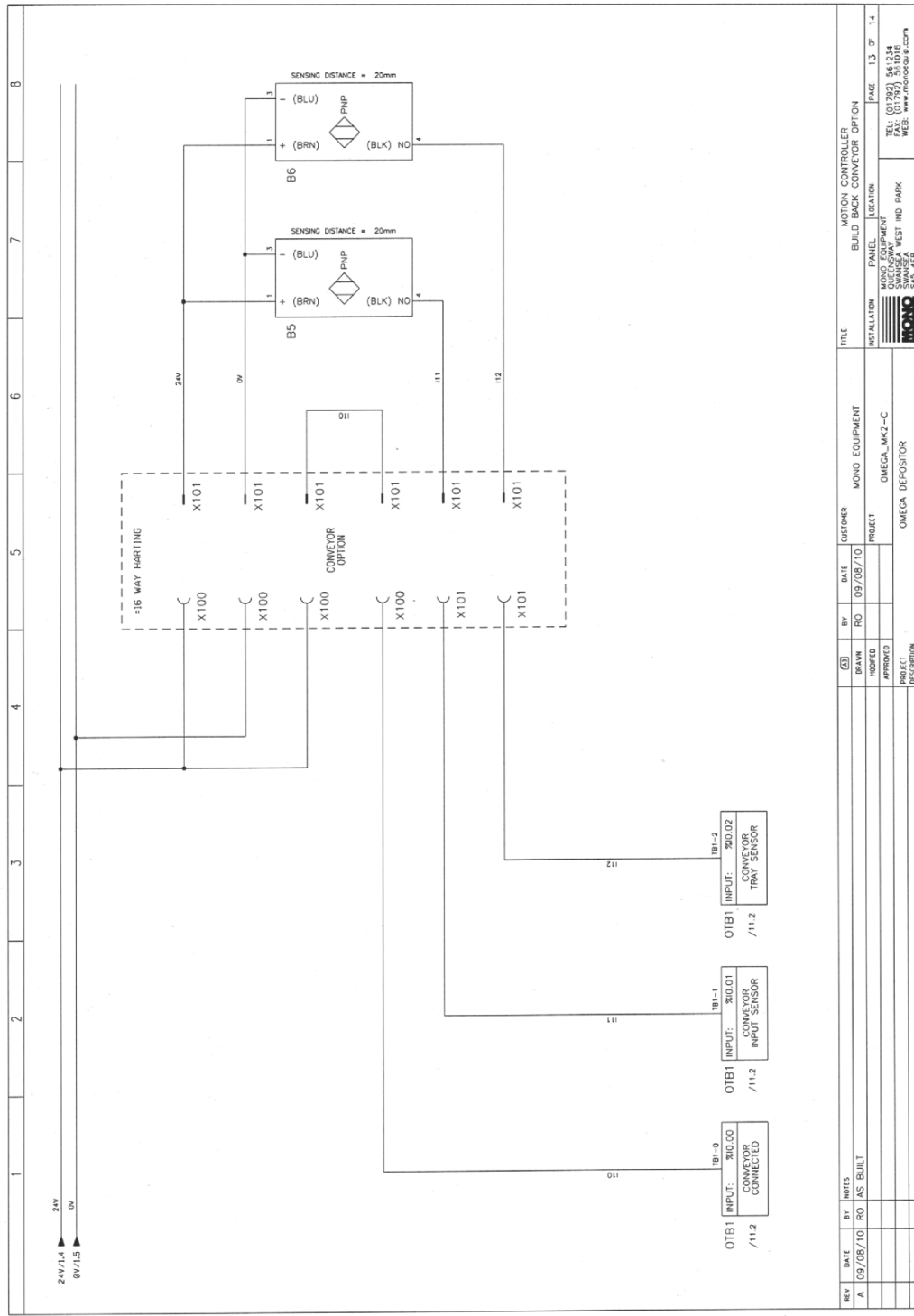

REV	DATE	BY	NOTES	TITLE
A	09/08/10	RO	AS BUILT	MOTION CONTROLLER BUILD BACK CONVECTOR OPTION
				INSTALLATION PANEL LOCATION
				MONO EQUIPMENT
				PROJECT OMEGA WK2-C
				OMEGA DEPOSITOR
				MONO
				LOCATION
				SWANSEA WEST IND PARK
				SWANSEA
				305 4EB
				SIZE 13.9" 14
				DATE 09/28/10
				TEL: (01782) 361324
				WEB: www.monobdy.pl.com



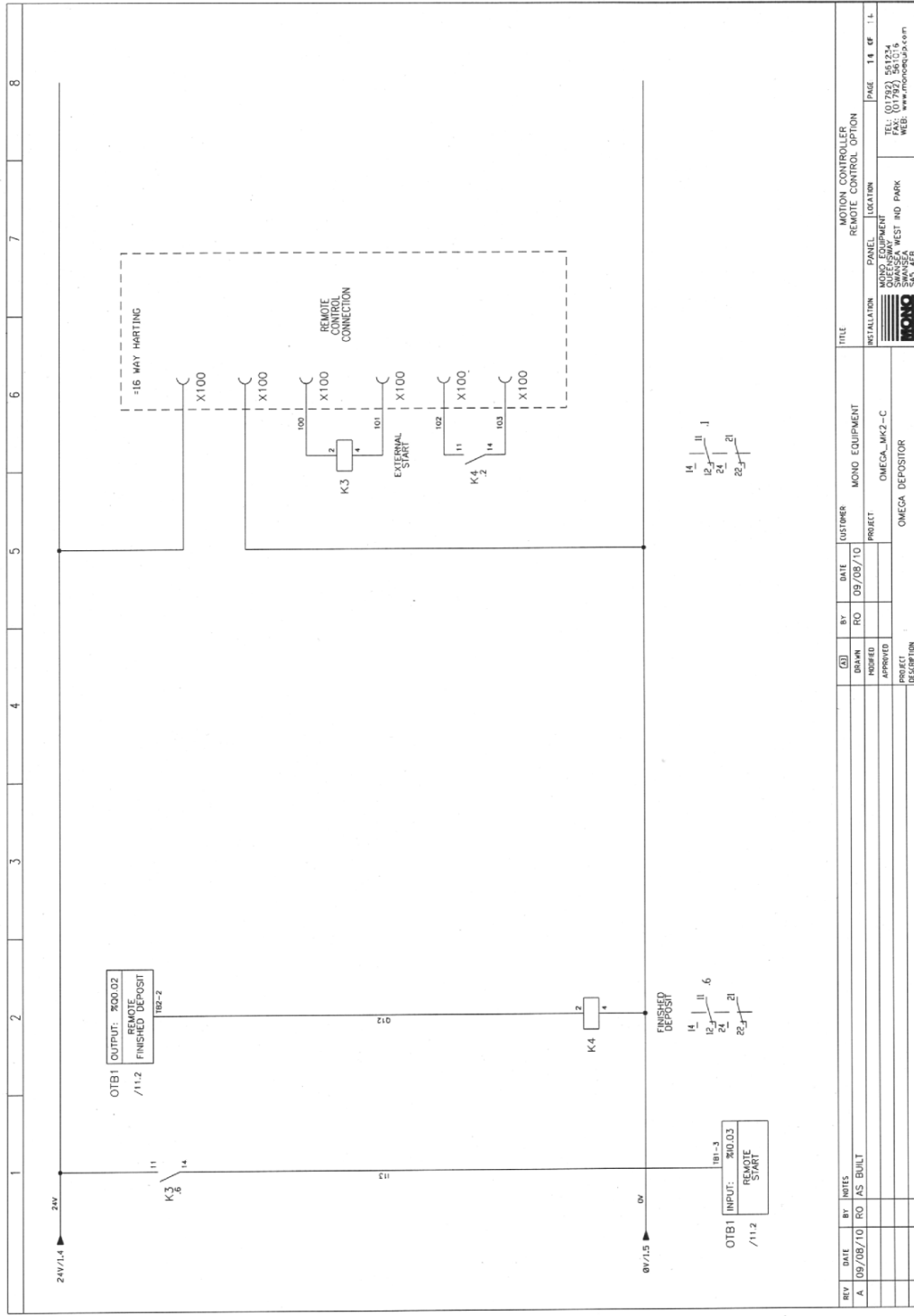

REV	DATE	BY	INITIALS	DESCRIPTION
A	09/08/10	RO	AS BUILT	

QTY	BY	DATE	CUSTOMER	MONO EQUIPMENT	TITLE	MOTION CONTROLLER
	RO	09/05/10	PROJECT	OMEGA_MK2-C	INSTALLATION	REMOTE CONTROL OPTION

INSTALLATION	PANEL	LOCATION	PAGE	OF	TOTAL
MONO	MONO	MONO	14	OF	14

CONTACT	DESCRIPTION
14	11
12	11
24	21
23	21



The equipment mentioned in this manual has CE accreditation.

As it is our policy to improve our machines continuously, we reserve the right to change specifications without prior notice



Omega PLUS

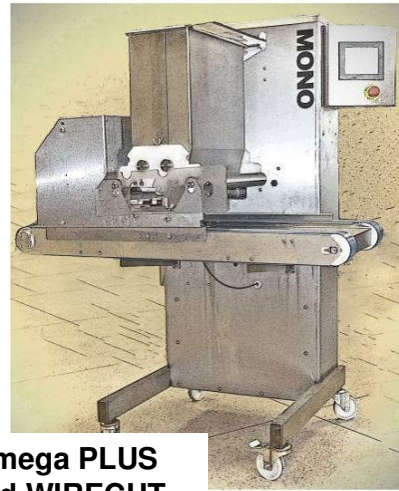

**Omega PLUS
And WIRECUT**



Queensway,
Swansea West Industrial Estate,
Swansea.
SA5 4EB
UK

Tel. +44(0)1792 561234

Spares Tel. +44(0)1792 564039

Fax. 01792 561016

Email: marketing@monoequip.com

Web site: www.monoequip.com

▪ **DISPOSAL**

Care should be taken when the machine comes to the end of its working life. All parts should be disposed of in the appropriate place, either recycling or other means as the law permits at the time.